

AK31 P.: Pneumatic damper drive

For continuous control or open/closed control of air dampers or similar control units in ventilation and air-conditioning systems. The actuator complies with EN 13463-1 and EN 1127-1 (Ex II 2 G T6) and can be employed in Zone 1 areas where there is a risk of explosion.

Housing of self-extinguishing plastic; roller membrane of silicon; drive spindle of stainless steel with M8 external thread; push-on nipple for connecting plastic tubing with internal diameter of 4 mm.

Type	Working range bar	max. force at		max. torque at		Permissible damper area ¹⁾ m ²	Weight kg
		0 bar N	1,2 bar N	0 bar Nm	1,2 bar Nm		
AK31 P1 F001	0,3...0,9	70	70	1,8	1,8	0,6	0,3
AK31 P2 F001	0,2...0,6	40	160	1	4	0,3	0,32
AK31 P3 F001	0,6...1,0	160	40	4	1	0,3	0,32

Control pressure	0...1,2 bar ²⁾	Air consumption for 100% stroke	
Max. permissible pressure	1,5 bar	AK31 P1	0,3 l _n
Effective area	30 cm ²	AK31 P2, P3	0,2 l _n
Stroke	50 mm	Perm. ambient temp.	-5...60 °C
Lever length for 90°	35 mm	Degree of protection	IP 20
Running time for 100% stroke ³⁾	5 s	Dimension drawing	M00965
		Fitting instruction	MV 505113

Accessories

- 0274587 000*** Fixing console
- 0274589 000*** Straight ball-joint with 2 nuts (M8)
- 0274591 000*** Fixing bracket with 4 screws Ø 5,5 × 13
- 0274593 000*** Angled ball-joint with 2 nuts (M8)
- 0370039 000*** Connecting nut, 2 locking nuts (M8)
- 0370040 000*** Threaded rod (M8), 500 mm long
- 0370059 000*** Clamping lever for shaft diameter 8...18 mm

^{*)} Dimension drawing or wiring diagram are available under the same number

- 1) Recommended value for equal-sided, easy-action air dampers.
In cases where the air dampers are tight-sealing in accordance with DIN 1946, the increased actuating power required to overcome the lamella seals must be taken into account.
- 2) Necessary for obtaining the actuating power.
See Section 60 on regulations concerning the quality of supply air, especially at low ambient temperatures.
- 3) Based on the Centair air capacity (400 l_n/h) and a line of 20 m length and 4 mm diameter

Operation

The spindle is extended as the control pressure increases, and retracted by the spring as the control pressure decreases. In order to attain the maximum actuating power at both 0 and 100% stroke, the control pressure must change from 0 to 1,2 bar. It is not possible to affix a positioner.

Fitting position

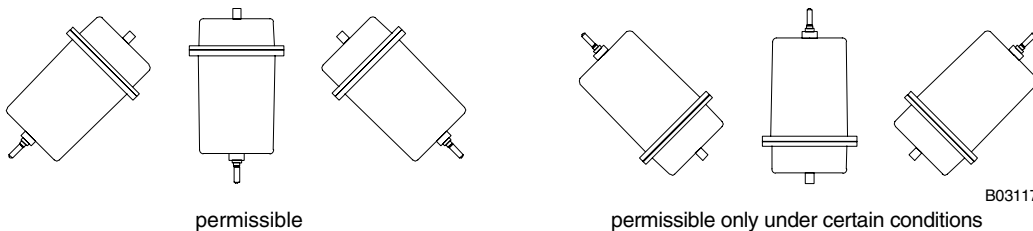

The ingress of condensate, water droplets etc. along the spindle and into the drive should be prevented.



T03067



Y07550

AK31 P1

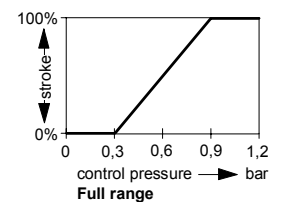

B00969

AK31 P2

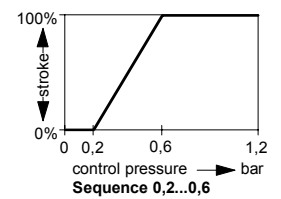

B00976

AK31 P3

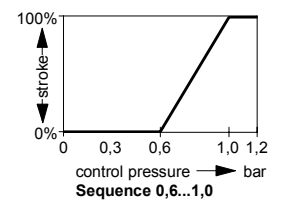

B00977

Dimension drawing

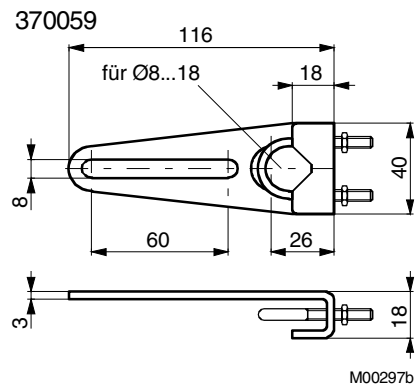
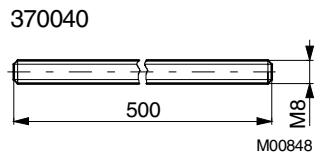
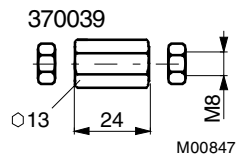
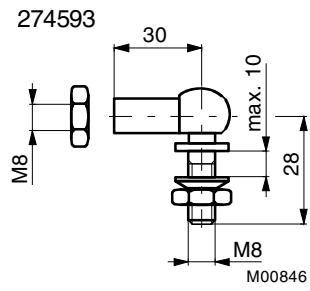
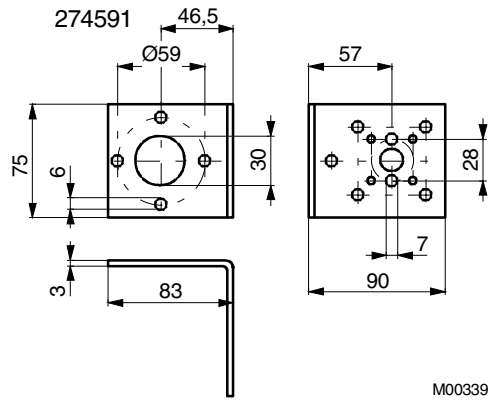
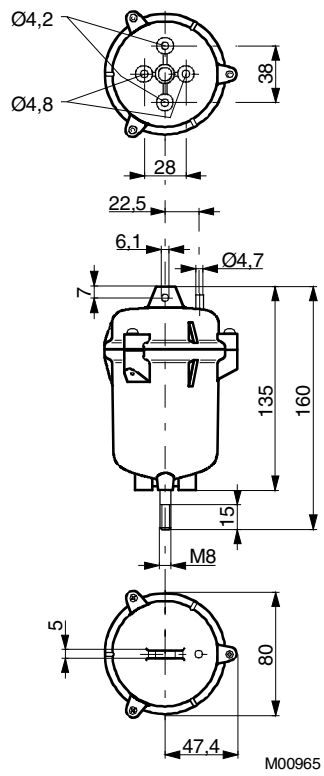

Accessories

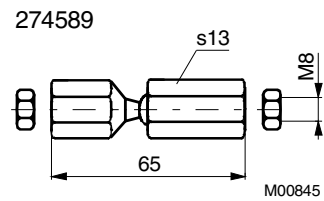
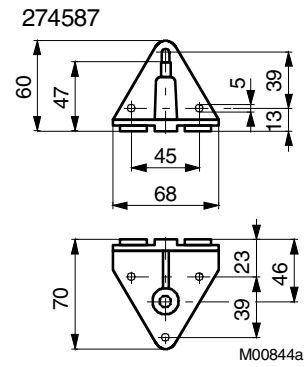

Fitting options

