

ASM 105, 115: Actuators

For controllers with switched output (two- or three-point control). For the operation of air dampers, cut-off dampers and multi-louvre dampers.

Two-piece housing of fire-retardant plastic, black lower part, yellow upper part. Synchronous motor with electronics for control and switch-off, magnetic clutch and maintenance-free gearbox. Electronic recognition of end position and motor switch-off using time-switch in the device. Self-centring spindle adaptor for fitting to the damper spindle. Gearbox can be de-coupled in order to position the damper or to make manual adjustments. Power cable is 1,2 metres long, 3 × 0,75 mm², fixed to the housing. Fixing bracket, which functions as an anti-torsion device, has two metal screws. Suitable for fitting in any position.



T09868



Y07551

Type ⁴⁾	Control	Torque Nm	Holding torque Nm	Running time for 90° s	Power	Weight kg
ASM 105 F100	2/3-point	5	5	30	230 V~	0,7
ASM 105 F120	2/3-point	5	5	120	230 V~	0,7
ASM 105 F122	2/3-point	5	5	120	24 V~	0,7
ASM 115 F120	2/3-point	10	10	120	230 V~	0,7
ASM 115 F122	2/3-point	10	10	120	24 V~	0,7

Power supply			Permissible ambient temp.	-20...65 °C ⁵⁾	
F100	230 V~	± 15%, 50 Hz	Permissible ambient humidity	5...95 %rh	
F12	230 V~	± 15%, 50...60 Hz	Degree of protection (horizontal)	IP 54 as per EN 60529	
	24 V~	± 20%, 50...60 Hz	Protection class	24 V	III as per IEC 60730
				230 V	II as per IEC 60730
Power consumption			Noise while running	< 30 dB(A)	
F100		2,4 W	4,5 VA	Response time	200 ms
F120		2,0 W	4,0 VA		
F122		1,6 W	1,7 VA		
Angle of rotation	90° ¹⁾		Wiring diagram	2-point	A10210
Damper spindle	Ø 8...16 mm			3-point	A09713
	□ 6,5...12,7 mm		Dimension drawing		M09736
Damper spindle (hardness)	Max. 300 HV		Fitting instructions		MV 506064
			Declaration of materials		MD 51.040

Accessories

0361977 002	Assembly kit for MH32 / MH42 control valve; MV 505840
0372145 001*	Single auxiliary change-over contacts ²⁾ ; MV 505795
0372145 002*	Double auxiliary change-over contacts ²⁾ ; MV 505795
0372286 001*	Potentiometer ³⁾ 130 Ω; MV 505795
0372286 002*	Potentiometer ³⁾ 1000 Ω; MV 505795
0372286 003*	Potentiometer ³⁾ 5000 Ω; MV 505795
0372300 001	Anti-torsion device, long (230 mm)
0372301 001	Spindle adaptor for squared-end (□15 mm) tubular section (batch package of 10 pieces)
0372320 001	Plastic Allen key for indicating the position
0372459 100*	External circuitry 230V version for parallel operation with ASM/AVM 104, 114 or actuators with end-switch, incl. distribution box; MV 506102
0372459 102*	External circuitry 24V version for parallel operation with ASM/AVM 104, 114 or actuators with end-switch, incl. distribution box; MV 506102

^{*)} Dimension drawing or wiring diagram are available under the same number

- 1) Maximum angle of rotation: 95° (without stops for the dampers)
- 2) Fully variable from 0...90°; max. loading 5 (2) A, 24...230 V
- 3) Only one potentiometer or one set of auxiliary contacts can be fitted to each drive!
- 4) Version with halogen-free cable available on request
- 5) Operating time approx. 80% up to 65 °C, 100% up to 55 °C

Operation

The final control element can be moved into any desired position by connecting the power supply. In 3-point control systems, the spindle adaptor turns (as viewed from the actuator towards the coupling) in a clockwise direction if power is connected to the brown wire, and in an anti-clockwise direction if connected to the black wire.

In 2-point control systems, the spindle adaptor turns (as viewed from the actuator towards the coupling) in a clockwise direction if power is connected to the brown wire, and in an anti-clockwise direction if no power is connected to the brown wire. The black wire always has power applied to it.

In the end positions (on reaching the stop in the air damper or on reaching the maximum angle of rotation) or in the event of overloading, the magnetic coupling responds. The control signal is switched off by the electronic cut-out after three minutes (60 seconds for F100). The effective end position is set by the damper stop or by the angle limiter, or by reaching the maximum angle of 95°.

Manual adjustment by de-coupling the gears (by pressing the button on the housing cover and moving the spindle adaptor at the same time).

In 3-point control systems, the direction of rotation can be changed by swapping the power-supply wires over.

Engineering and fitting notes

The concept of the synchronous motor allows several dampers to be run in parallel. The actuator can be mounted in any position (including upside down). It can be put directly onto the damper shaft and clipped onto the anti-torsion device. The self-centring spindle adaptor ensures that the damper spindles are operated smoothly. The damper drive can easily be removed from the damper spindle without having to take off the anti-torsion device.

The angle of rotation can be limited between 0 and 90°, and set anywhere between 5° and 80°. The limit is set by means of a screw on the drive itself and with the stop on the self-centring spindle adaptor. The spindle adaptor is suitable for damper spindles of Ø 8...16 mm, □ 6,5...12,7 mm.

The following accessories can be fitted to each actuator: one set of auxiliary contacts or a potentiometer.

The auxiliary contacts should be screwed onto the drive's top cover. Before the mechanical connection can be established, the indicator knob should be removed. A new indicator is then visible on the lid of the auxiliary contacts.

N.B.: The housing should not be opened.

Fitting outdoors. If the devices are fitted outdoors, we recommend that additional measures be taken to protect them against the effects of the weather.

Additional technical data

The upper part of the housing, with the lid and indicator knob, contains the synchronous motor with the capacitor. The lower part contains the maintenance-free gears and the gear-release knob. To reverse the direction of operation in 3-point control systems, the brown and the black wires should be transposed. The actuators are protected against incorrect connection.

Auxiliary change-over contacts

Switch rating: max. 230 V a.c.; min. current 20 mA at 20 V

Switch rating: max. 4...30 V d.c.; min. current 1...100 mA

Power consumption:

Type	Running time s	Condition	active power P W	apparent power S VA
ASM 105 F100	30	Operating	2,4	4,5
ASM 105 F120	120	Operating	2,0	4,0
ASM 105 F122	120	Operating	1,6	1,7
ASM 115 F120	120	Operating	2,0	4,0
ASM 115 F122	120	Operating	1,6	1,7

CE conformity

EMC directive 2004/108/EC

EN 61000-6-1

EN 61000-6-2

EN 61000-6-3

EN 61000-6-4

Machine directive 98/37/EEC (II B)

EN 1050

Low-voltage directive 2006/95/EC *)

EN 60730-1

EN 60730-2-14

Over-voltage category III

Degree of pollution II

*) For ASM 1 . 5 F1 . 0 only

Wiring diagram

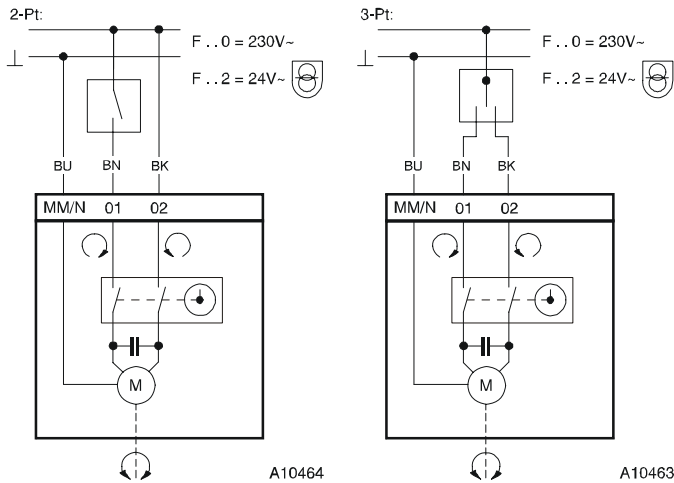

Direction of operation 1:
01 closed, 02 open
Direction of operation 2:
02 closed, 01 open

Accessories

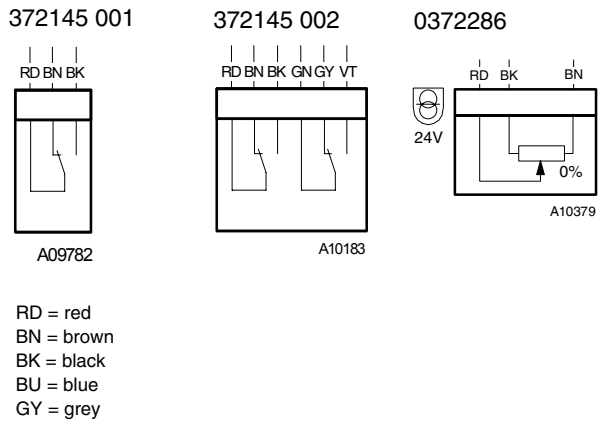

Dimension drawing

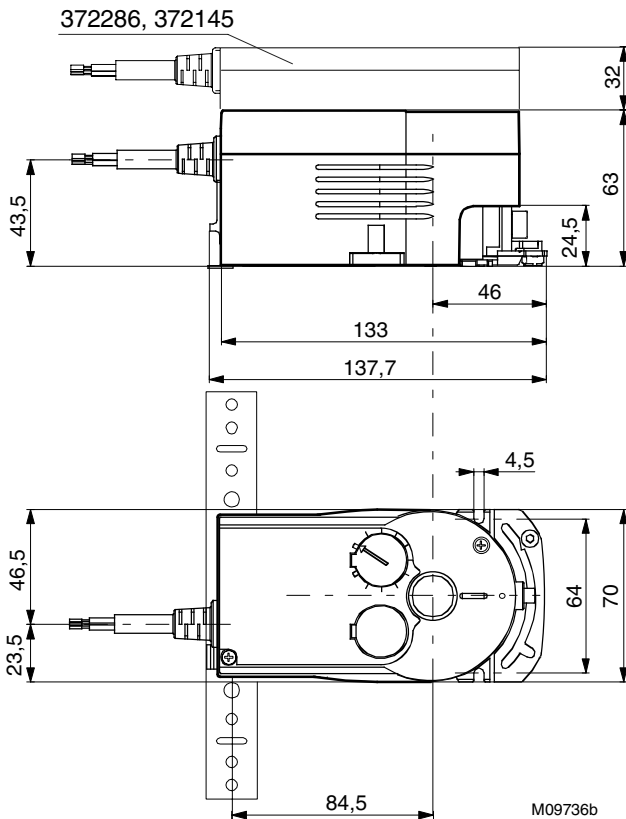

372459 10 .

