

ASM 105S, 115S: Actuators with Sauter Universal Technology (SUT)

For controllers with continuous output (0...10 V) or switched output (two- or three-point control). For the operation of air dampers, cut-off dampers and multi-louvre dampers.

Two-piece housing of fire-retardant plastic, black lower part, yellow upper part. With stepping motor, SUT electronic control unit and maintenance-free gears. Self-centring spindle adaptor for fitting to the damper spindle. Direction of operation can be changed at the cable. Electronic, torque-based cut-out via stops on either the actuator or the air damper. Coding switch for choosing the running time and initialising function. Gearbox can be de-coupled in order to position the damper or to make manual adjustments. Power cable is 1,2 metre long, 5× 0,50 mm² and is fixed to the housing. Fixing bracket, which functions as an anti-torsion device, has two metal screws. Suitable for fitting in any position.

Type ⁵⁾	Torque	Holding torque	Running time for 90°	Power	Weight
	Nm	Nm	s		kg
ASM 105S F132	5	5	35 / 60 / 120	24 V~/=	0,7
ASM 115S F132	10	10	60 / 120	24 V~/=	0,7

Positioner ¹⁾			
Control signal y	0...10 V, Ri > 100 kΩ	Starting point U0	0 or 10 V
Positional feedback signal yo	0...10 V, load >10 kΩ	Control span ΔU	10 V
		Switching range Xsh	200 mV

Power supply	24 V~ 24 V=	± 20%, 50...60 Hz ± 20%	Ambient temperature	-20...55 °C
Power consumption			Ambient humidity	< 95 %rh without condensation
ASM 105S F132	5,0 W	9,0 VA	Protection (horizontal)	IP 54 as per EN 60529
ASM 115S F132	4,8 W	8,7 VA	Protection class	III as per IEC 60730
Angle of rotation	90° ²⁾		Noise while running	< 30 dB(A)
Damper spindle	Ø 8...16 mm; □ 6,5...12,7 mm		Response time ¹⁾	200 ms
Damper spindle (hardness)	max. 300 HV		Wiring diagram	A10465
			Dimension drawing	M09736
			Fitting instructions	MV 506064
			Declaration of materials	MD 51.041



T09869



Y07552

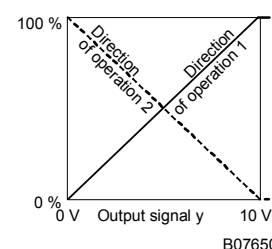

B07650

Accessories

0313529 001*	Split-range unit for setting sequences; to be fitted in separate distribution box as per MV 505671
0361977 002	Assembly kit for MH32 / MH42 control valve; MV 505840
0372145 001*	Auxiliary change-over contacts ³⁾ , single, MV 505795
0372145 002*	Double auxiliary change-over contacts ³⁾ ; MV 505795
0372286 001*	Potentiometer ⁴⁾ 130 Ω; MV 505795
0372286 002*	Potentiometer ⁴⁾ 1000 Ω; MV 505795
0372286 003*	Potentiometer ⁴⁾ 5000 Ω; MV 505795
0372300 001	Anti-torsion device, long (230 mm)
0372301 001	Spindle adaptor for squared-end (□15 mm) tubular section (batch package of 10 pieces)
0372320 001	Plastic Allen key for indicating the position
0372462 001	CASE Drives PC Tool for configuration of actuators per computer; MV 506101

*) Dimension drawing or wiring diagram are available under the same number.

- 1) Also for 2-point or 3-point, depending on type of connection
- 2) Maximum angle of rotation: 95° (without stops for the dampers)
- 3) Fully variable from 0...90°; max. loading 5 (2) A, 24...230V
- 4) Only one potentiometer or one set of auxiliary contacts can be fitted to each drive!
- 5) Version with halogen-free cable available on request

Operation

Depending on how it is connected (see wiring diagram), the actuator can be used as a continuous 0...10 V, as a 2-point (open/close) or as a 3-point drive (open/stop/close) with intermediate position. The running time can be matched to requirements using switches S1 and S2. Manual adjustment by de-coupling the gears (by pressing the button next to the power cable and moving the spindle adaptor at the same time).

Connected as a 2-point control unit

Open/close activation can be effected via two wires. Power is applied to the drive via the blue and the brown wires. On connecting power to the black wire, the damper drive moves to the end position (clockwise direction to 100% angle of rotation). When power is switched off, the drive goes to the opposite end position. The unused red and grey wires should not be connected, nor should they come into contact with other wires. We recommend that you insulate them.

Connected as a 3-point control unit

By connecting power to the wires (black or brown), the damper drive can be moved to any position. Angle of rotation (as viewed from the actuator towards the spindle adaptor):

- The spindle adaptor turns in a clockwise direction if power is applied to the black wire.
- The spindle adaptor turns in an anti-clockwise direction if power is applied to the brown wire.

In the end positions (the damper's end position; the end position due to the angle-of-rotation limit; on reaching the maximum angle of rotation of 95°) or in the event of an overload, the electronic motor cut-off responds (no end switches). The direction of rotation can be changed by transposing the connections.

The unused red and grey wires should not be connected or come into contact with other wires. We recommend that they be insulated.

Connections for control voltage 0...10 V

The integrated positioner controls the drive as a function of the controller's positioning signal y .

Angle of rotation (as viewed from the actuator towards the spindle adaptor):

- Direction of operation 1 (mains power at brown wire): the spindle adaptor turns in a clockwise direction as the positioning signal rises.
- Direction of operation 2 (mains power at black wire): the spindle adaptor turns in an anti-clockwise direction as the positioning signal rises.

The starting point and the control span are both pre-set.

Either the brown or the black wire should be connected, depending on the direction of operation. The unused wire should be insulated.

After power has been applied, the stepping motor moves to both stops one after the other and determines its effective angle of rotation (always with a running time of 60 seconds). Thanks to the electronics unit, no steps are lost, and the drive needs no periodical re-adjustment. After manual adjustments have been made, or when there is a power failure lasting longer than 5 minutes, the drive re-adjusts itself automatically. Whenever the angle of rotation is altered, a re-adjustment must be initiated (by manual adjustment) so that the drive, the control voltage and the feedback signal can adapt themselves to the new angle of rotation. Automatic initialisation can be switched off using switch S3. The actuator now works in either manual or controlled initialisation mode, and must be moved either manually to the stops by the controller's output signal, or automatically in the control loop by the control behaviour. If it detects a new stop, it saves it, and the feedback signal is adapted accordingly. Afterwards the current position can be calculated and issued.

If the control signal (0...10 V) is interrupted and direction of operation 1 is set, the damper closes fully (0% position).

Coding switch

ASM 105S	ASM 115S	S1	S2	S3
90°	90°	S1	S2	S3
120s	120s	off	on	–
120s	120s	on	on	–
60s	60s	on	off	–
35s	60s	off	off	–
Initialisation on		–	–	on
Initialisation off		–	–	off
ex-works position		on	on	on

CASE Drives PC Tool, Accessory 0372462 001

CASE Drives enables all the actuator's parameters to be set and viewed on site. Connection is via a serial port on the PC (laptop) and a socket on the actuator. The set comprises: software including installation and operating instruction, fitting instructions, connectors, cable (1,2 metres in length) and an interface converter for the PC. The application is designed for commissioning and service technicians and for experienced users.

The last setting (i.e. whether with coding switch or CASE Drives) has priority. This setting is active when the valve's running time or characteristic is changed via the coding switch. To ensure that the settings with CASE Drives cannot be overwritten, the coding switch should be removed before setting values through CASE Drives (special tool included).

Split-range unit, Accessory 0361529 001

The starting point U0 and the control span ΔU can be set using the potentiometer. This makes it possible to activate several regulating units in sequence or in cascade using the controller's control signal. The input signal (partial range) is amplified into an output signal of 0...10 V. This accessory cannot be fitted in the drive, but should be located externally in an electric distribution box.

Engineering and fitting notes

The combination of stepping motor and electronics allows several air dampers with different torque levels to be run in parallel, if drives of the same SUT type are used. The actuator can be mounted in any position (included upside down). It can be put directly onto the damper shaft and clipped onto the anti-torsion device. The self-centring spindle adaptor ensures that the damper spindles are operated smoothly. The damper drive can easily be removed from the damper spindle without having to take off the anti-torsion device.

The coding switches are accessible via a prepared opening with black lid in the housing cover.

The angle of rotation can be limited between 0 and 90°, and set anywhere between 5° and 80°. The limit is set by means of a screw on the drive itself and with the stop on the self-centring spindle adaptor. The spindle adaptor is suitable for damper spindles of \varnothing 8...16 mm, \square 6,5...12,7 mm.

The following accessories can be fitted to each actuator: one set of auxiliary contacts (single or double).

The auxiliary contacts should be screwed onto the drive's top cover. Before the mechanical connection can be established, the indicator knob should be removed. A new indicator is then visible on the lid of the auxiliary contacts.

N.B.: The housing should not be opened.

Fitting outdoors

If the devices are fitted outdoors, we recommend that additional measures be taken to protect them against the effects of the weather.

Additional technical data

The upper part of the housing, with the lid, indicator knob and the cap, contains the stepping motor and the SUT electronic control unit. The lower part contains the maintenance-free gears, the gear-release lever and the spindle adaptor.

Auxiliary change-over contacts

Switch rating: max. 230 V a.c.; min. current 20 mA at 20 V

Switch rating: max. 4...30 V d.c.; current 1...100 mA

Power consumption:

Type	Running time s	Condition	active power P W	apparent power S VA
ASM 105S F132	35	Operating	2,8	5,3
		Standstill	1,6	3,2
	60	Operating	5,0	9,0
		Standstill	1,6	3,2
	120	Operating	2,4	4,5
		Standstill	1,6	3,2
ASM 115S F132	60	Operating	4,8	8,7
		Standstill	1,5	3,0
	120	Operating	3,5	6,5
		Standstill	1,5	3,0

CE conformity

EMC directive 2004/108/EC

EN 61000-6-1

EN 61000-6-3

EN 61000-6-4

Machine directive 98/37/EEC (II B)

EN 1050

Wiring diagram

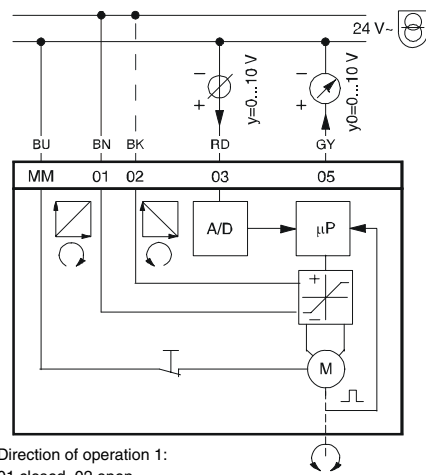

Direction of operation 1:
01 closed, 02 open
Direction of operation 2:
02 closed, 01 open

Variante 1 (3pt)

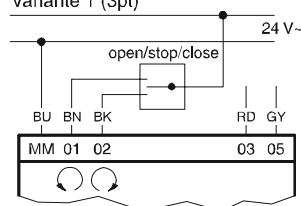

Variante 2 (2pt)

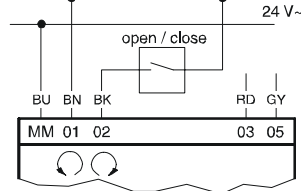

A10465

RD = red
BN = brown
BK = black
BU = blue
GY = grey

Dimension drawing

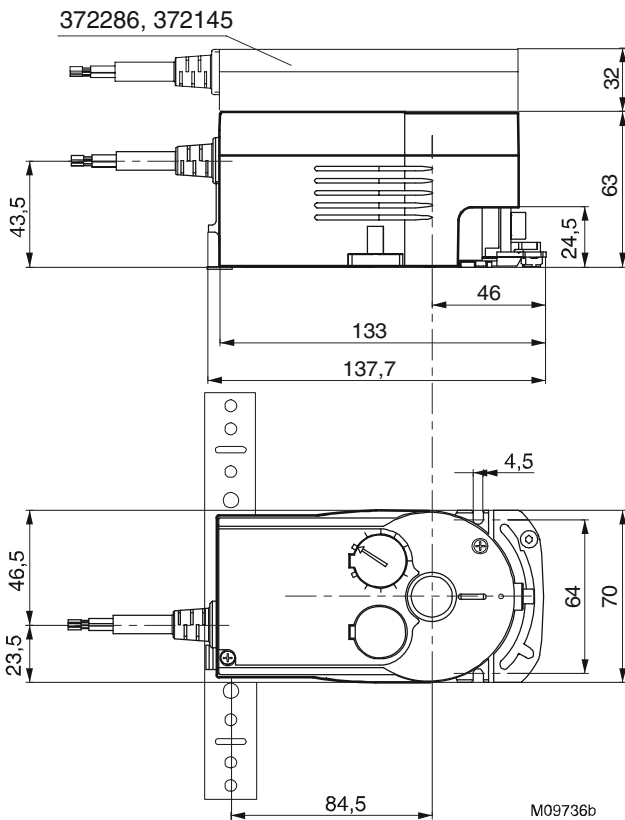

Accessories

372145 001

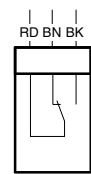

A09782

372145 002

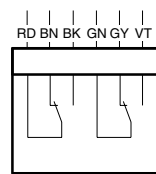

A10183

0372286

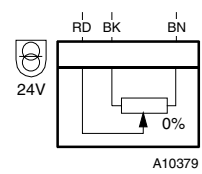

A10379

0313529

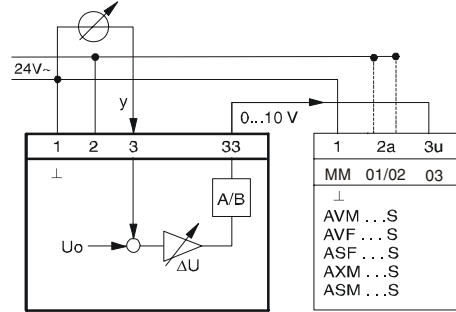

A09421c