

DEF: Wafer butterfly valve, tightly-closing, PN 16

For continuous control of water, air and low-pressure steam flow up to 110 °C.
Butterfly body made of cast iron (GG25) to fit flanges PN 6, PN 10 and PN 16; blue hammer- enamel finish. Drive flange acc. to EN ISO 5211. Butterfly disc made of stainless steel. Ethylene-propylene rubber collar. Stainless-steel spindle sealed with 2 O-ring packings.



T04237



Y07548

Type	Nominal width		k_{VS} value m ³ /h	Weight kg
	DN			
DEF 025 F200	25		36	1
DEF 032 F200	32		40	1,15
DEF 040 F200	40		50	2,75
DEF 050 F200	50		85	3,05
DEF 065 F200	65		215	4,05
DEF 080 F200	80		420	4,30
DEF 100 F200	100		800	4,85
DEF 125 F200	125		1010	7,20
DEF 150 F200	150		2100	9,50
DEF 200 F200	200		4000	12

Nominal pressure	PN 16	Dimension drawings	5M109
Max. perm. operating pressure	16 bar	Fitting instructions	MV 505826
Control characteristic	linear	Assembly ASF	MV 505833
Angle of butterfly rotation	90°	Assembly AR30	MV 505831
Leakage rate ¹⁾	< 0,0001% of k_{VS} ¹⁾	Assembly A44	MV 505832
Permissible operating temperature	-10...130 °C		

Accessories

0361632 . . . 2 counter flanges compl. PN 6 acc. to EN 1092-1
DN 25 32 40 50 65 80 100 125 150 200

0361633 . . . 2 counter flanges compl. PN 10 (DN 25...150) acc. to EN 1092-1
VSM 18717 (DIN 2632) and PN 16 (DN 25...200) acc. to EN 1092-1
DN 25 32 40 50 65 80 100 125 150 200

Specify when ordering: DN 25 = /025, DN 100 = /100

0361634 200 2 counter flanges compl. PN 10 (DN 200) acc. to EN 1092-1
0361734 001 Butterfly body outside surfaces, cold galvanized DN 25...125
0361734 002 Butterfly body outside surfaces, cold galvanized DN 150, 200
0378108 001 Assembly kit; DEF DN 25-65 for AR 30
0378109 001 Assembly kit; DEF DN 80-100 for AR 30
0378110 001 Assembly kit; DEF DN 25-65 for A44
0378111 001 Assembly kit; DEF DN 80-125 for A 44
0378112 001 Assembly kit; DEF DN 150-200 for A44
0378113 001 Assembly kit; DEF DN 25-100 for ASF 122/123

¹⁾ at Δp 1,5 bar

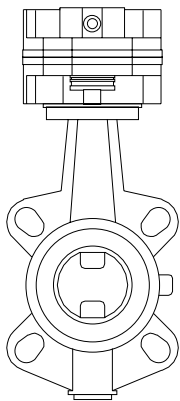

B06331

Combination with actuator with return spring:

Drive ¹⁾	Input		ASF 122 F120	ASF 123 F122	ASF 123S F122
	Running time	Spring return	2-point 90 s 15 s	3-point 90 s 15 s	0...10 V 90 s 15 s
Butterfly valve:	Δp ²⁾	Δp_S ³⁾			
DEF 025 F200	10	10			
DEF 032 F200	10	10			
DEF 040 F200	10	10			
DEF 050 F200	10	10			
DEF 065 F200	7	7			
DEF 080 F200	4	4			
DEF 100 F200	2	2			

- 1) Assembly kit 0378113 001 required (weight 0,5 kg)
 2) Max. permissible pressure difference in bar
 3) Max. differential pressure at the butterfly valve in bar (in the event of malfunction) at which the drive can still close the butterfly.

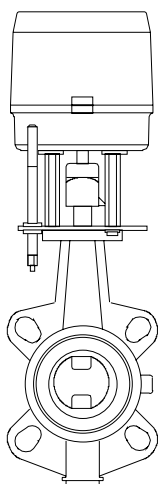

B01425a

Combination with electric motor drive AR30 W2.

Drive ¹⁾	Input		AR30 W23	AR30 W23S
	Running time		3-point 120 s	0...10 V 120 s
Butterfly valve	Δp ²⁾			
DEF 025 F200	10			
DEF 032 F200	10			
DEF 040 F200	10			
DEF 050 F200	10			
DEF 065 F200	7			
DEF 080 F200	4			
DEF 100 F200	2			

- 1) For DN 25...65: Assembly kit 0378108 001 required (weight 0,4 kg)
 For DN 80 and 100: Assembly kit 0378109 001 required (weight 0,4 kg)
 2) Permissible pressure difference in bar

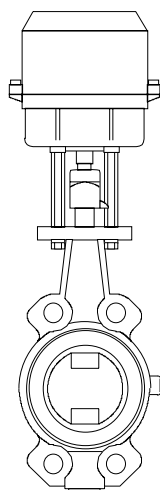

B01426

Combination with electric motor drive A44

Drive ¹⁾	Input		A44 W2	A44 W2S
	Running time		3-point 120 s	0...10 V 120 s
Butterfly valve	Δp ²⁾			
DEF 025 F200	10			
DEF 032 F200	10			
DEF 040 F200	16			
DEF 050 F200	16			
DEF 065 F200	16			
DEF 080 F200	10			
DEF 100 F200	10			
DEF 125 F200	6			
DEF 150 F200	5			
DEF 200 F200	3			

- 1) For DN 25...65: Assembly kit 0378110 001 required (weight 0,2 kg)
 For DN 80...125: Assembly kit 0378111 001 required (weight 0,2 kg)
 For DN 150 and 200: Assembly kit 0378112 001 required (weight 0,2 kg)
 2) Permissible pressure difference in bar

Complete type designation: Butterfly valve and drive with corresponding F-version
 Butterfly valve: F-version, technical data and accessories: see table of types on page 1
 Drive: F-version, technical data and accessories: see section 51
 Example: DEF 65 F200/ASF 123S F122

Operation

Can be actuated by means of motor drive or actuator with spring-return action to attain any intermediate position. Can be used as a shut-off device in conjunction with actuator ASF 122 / 123. In this case, the butterfly is actuated such that it will move either to its closed or open position in the event of a power failure or whenever a limiter comes into operation.

Manual butterfly adjustment:

- AR30 by means of a hand crank (mounted in the adapter plate)
- A44 W by means of a hand crank (mounted under the hood)
- ASF 122 / 123 manually after the coupling has been released

Information for engineering and installation

The butterfly valve is installed by clamping and then screw-mounting the unit between two flanges. The butterfly must be opened to at least 10% during installation. A special lining of the housing eliminates the need for flange gaskets.

Flow admission is possible from either side.

Additional design information

Design length of the butterfly valve acc. to EN 558 series 20 from nominal diameter 40. Collar is lined such that no contact between cast iron medium is possible.

Drive flange acc. to EN ISO 5211 NFE 29-402

Flange accommodation acc. to DIN 2501

DN	Directive on pressure equipment		CE
25	97 / 23 / EG	Art. 33	–
32	97 / 23 / EG	Art. 33	–
40	97 / 23 / EG	Art. 33	–
50	97 / 23 / EG	Art. 33	–
65	97 / 23 / EG	Cat. I	CE
80	97 / 23 / EG	Cat. I	CE
100	97 / 23 / EG	Cat. I	CE
125	97 / 23 / EG	Cat. I	CE
150	97 / 23 / EG	Cat. I	CE
200	97 / 23 / EG	Cat. I	CE

Dimension drawings 5M109

DEF 25...65

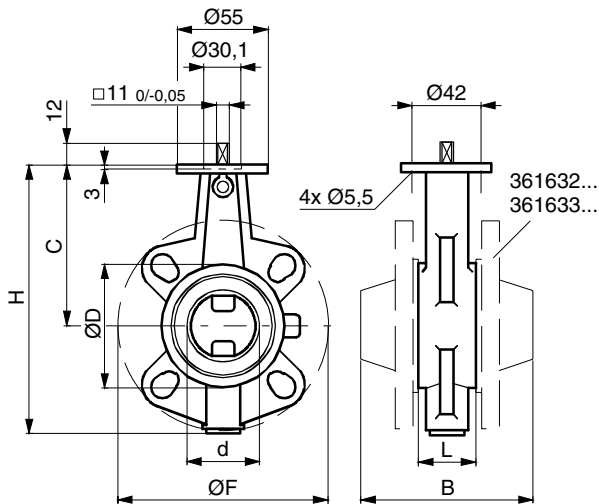

DN	d	C	H	L	ØD	B		ØF	
						PN6	PN10/16	PN6	PN10/16
25	32	104	149	33	64	103	109	100	115
32	32	104	154	33	69	103	113	120	140
40	40	113	178	33	82	109	117	130	150
50	50	126	209	43	95	119	133	140	165
65	62	134	226	46	115	122	136	160	185

M10016

DEF 80...200

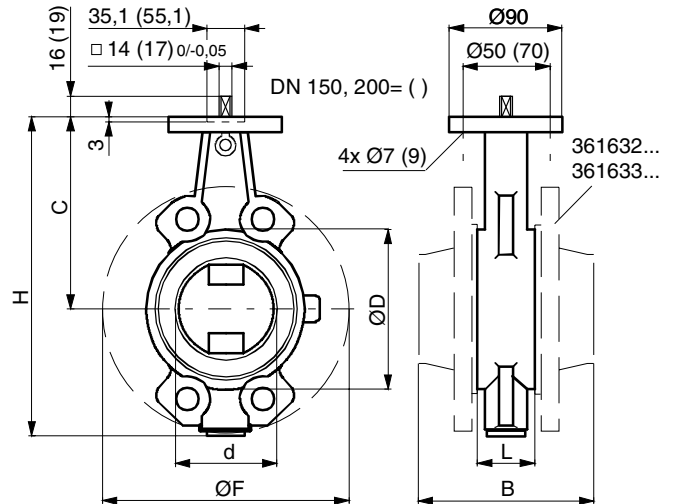

DN	d	C	H	L	ØD	B		ØF	
						PN6	PN10/16	PN6	PN10/16
80	78	157	260	46	138	130	146	190	200
100	98	167	281	52	158	142	156	210	220
125	123	180	306	56	188	152	166	240	250
150	147	203	355	56	212	152	166	265	285
200	197	228	403	60	250	170	182	320	340

M10017

with drive A44

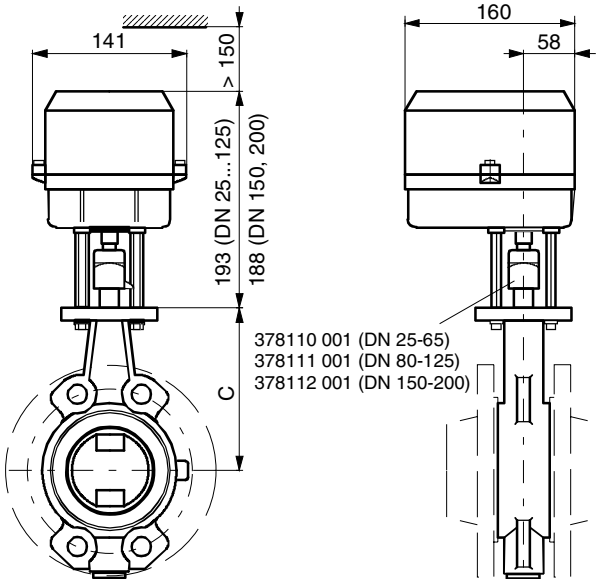

K10018

with drive AR30

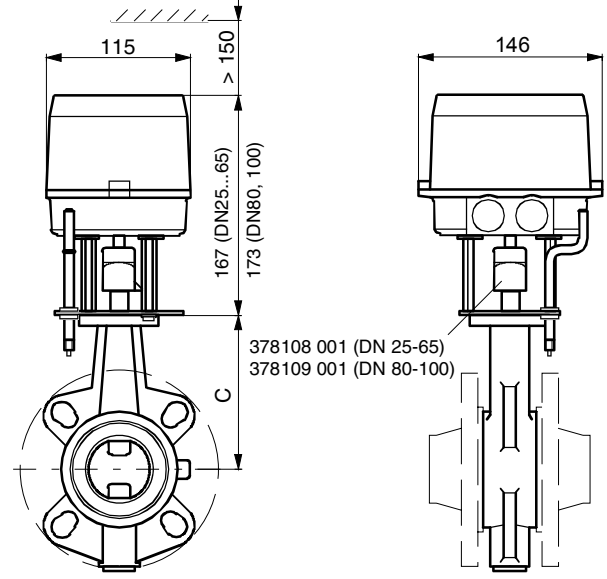

K10019

DN 25...100 with drive ASF 122, ASF 123

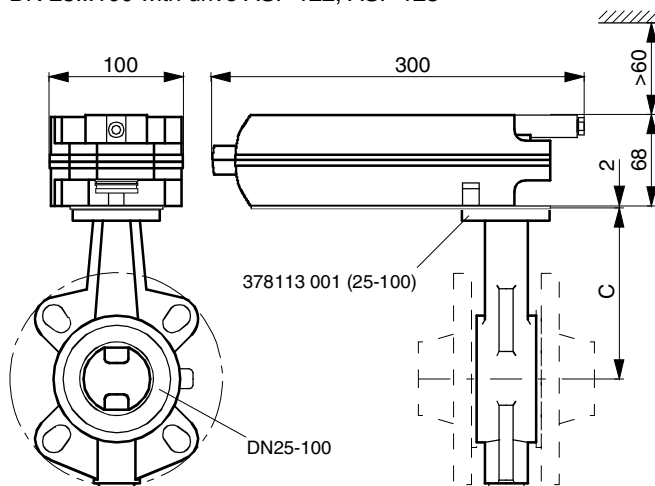

K06332b