

**B6R: Three-way valve with female thread; PN 16**

For continuous control of hot and cold water or of air. Valve body of bronze (Rg 5). Valve seat of bronze, valve spindle of stainless steel, valve plug of either stainless steel or brass, metallic sealing. Stuffing box of brass with O-ring seal. Valve curve either equal percentage or linear. When spindle is extracted, passage A-AB is closed.

Type	Nominal diameter DN	$k_{VS}$ -value m <sup>3</sup> /h	Valve plug material	Weight kg
<b>B6R 15 F330</b>	15	1	stainless steel	1,2
<b>B6R 15 F320</b>	15	1,6	stainless steel	1,2
<b>B6R 15 F310</b>	15	2,5	brass	1,2
<b>B6R 15 F300</b>	15	4	brass	1,2
<b>B6R 25 F310</b>	25	6,3	brass	1,6
<b>B6R 25 F300</b>	25	10	brass	1,6
<b>B6R 40 F310</b>	40	16	brass	3,4
<b>B6R 40 F300</b>	40	25	brass	3,4
<b>B6R 50 F300</b>	50	35	brass	4,6

Operating temperature <sup>1)</sup>	-15...130 °C		Leakage rate flow A-AB	≤ 0,05% of $k_{VS}$ -value
Operating pressure	up to 120 °C	16 bar	Mixing flow B-AB	≤ 1% of $k_{VS}$ -value
	up to 130 °C	13 bar	Dimension drawings	<a href="#">5M100</a>
Valve curve	equal-percentage or linear		Fitting instructions	MV 505574
Control ratio	50 (typical)		AVM 234 / Assembly	MV 505919
Valve stroke	14 mm		AVF 234 / Assembly	MV 505920
			AVN 224 / Assembly	MV 505927

**Variants**

**-F2 . . .** Valve linear curve (available from DN 15,  $k_{VS}$  4 m<sup>3</sup>/h only)

**Accessories**

**0217268 . . .** Stuffing-box heating 15 W; N.B. 24 V = /001, 230 V = /004, MV 505498

**0360429 000** Sticker for distributor valve

**0360391 . . .** Union piece incl. asbestos-free seal, 3 pieces required; specify when ordering: DN 15 = /015, DN 25 = /025 etc.

DN	15	25	40	50
----	----	----	----	----

**0378034 001** Valve with packing box, silicon-free; synthetic lubricant; max. 130 °C

<sup>1)</sup> At temperatures under 0 °C, use stuffing-box heating (accessory)



T04417

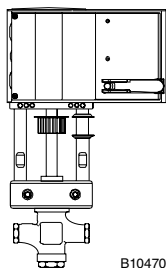

Y07545

**Combination B6R with electric actuator**  
 without spring return:

B10470

<b>Actuator</b>		<b>AVM 234S F132-5</b>				
Type:		<b>2 / 4 / 6 s/mm</b>				
Running time:		<b>2pt / 3pt; 0...10 V / 4...20 mA</b>				
Input:		<b>2pt / 3pt; 0...10 V / 4...20 mA</b>				
Valve	Closes against the pressure			Closes with the pressure		
	$\Delta p_{max}$	close-off pressure		$\Delta p_{max}$	close-off pressure	
<b>B6R 15 F300</b>	4	16		3	16	
<b>B6R 25 F300</b>	4	16		2	16	
<b>B6R 40 F300</b>	3	14,4		1,5	13,1	
<b>B6R 50 F300</b>	2	10,8		1	10,3	

with spring return:

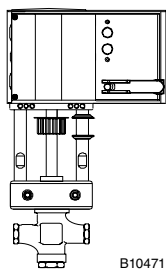

B10471

<b>Actuator</b>		<b>AVF 234S F132-5</b>					
Type:		<b>2 / 4 / 6 s/mm</b>					
Running time:		<b>2pt / 3pt; 0...10 V / 4...20 mA</b>					
Input:		<b>2pt / 3pt; 0...10 V / 4...20 mA</b>					
Spring return:		<b>15 - 30 s</b>					
Valve	Closes against the pressure			Closes with the pressure			
	$\Delta p_{max}$	$\Delta p_s$	close-off pressure	$\Delta p_{max}$	$\Delta p_s$	close-off pressure	
<b>B6R 15 F300</b>	4	16	16	3	16	16	
<b>B6R 25 F300</b>	4	12	16	2	16	16	
<b>B6R 40 F300</b>	3	3	11,5	1,5	16	10,4	
<b>B6R 50 F300</b>	2	2	8,6	1	16	7,9	

with safety function:

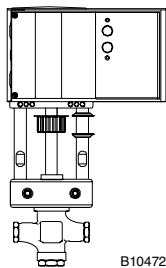

B10472

<b>Actuator</b>		<b>AVN 224S F132-5</b>					
Type:		<b>2 / 4 / 6 s/mm</b>					
Running time:		<b>2pt / 3pt; 0...10 V / 4...20 mA</b>					
Input:		<b>2pt / 3pt; 0...10 V / 4...20 mA</b>					
Safe function:		<b>15 - 30 s</b>					
Valve	Closes against the pressure			Closes with the pressure			
	$\Delta p_{max}$	$\Delta p_s$	close-off pressure	$\Delta p_{max}$	$\Delta p_s$	close-off pressure	
<b>B6R 15 F300</b>	4	16		3	16	16	
<b>B6R 25 F300</b>	4	16		2	16	16	
<b>B6R 40 F300</b>	3	6,3		1,5	16	5,5	
<b>B6R 50 F300</b>	2	4,7		1	16	4,2	

 $\Delta p_{max}$ [bar]= Max. permissible pressure difference across the valve at which the drive can still firmly open and close the valve.

 $\Delta p_s$  [bar]= Max. permissible pressure difference across the valve at which, in the event of a malfunction, the drive can close the valve.

Close/off pressure The pressure difference across the valve in control mode that can overcome the force of the drive. In this mode, a reduced serviceable life can be expected. Cavitation, erosion and pressure surges may damage the valve. The values stated apply only when the valve is fitted on the drive.

## Operation

Using an electric or hydraulic drive, the valve can be moved to any position.

### Used as a mixing valve

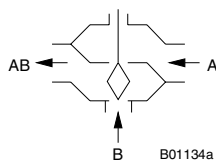

### Used as a distributor valve

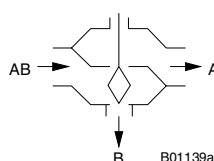

## Engineering and installation notes

Can be fitted in any position except facing downwards (see relevant drive). When fitting the drive to the valve, care must be taken not to turn the valve plug on the two stops (seat), thus damaging the seal.

When insulating the valve, the insulation should not extend beyond the connecting clamp on the drive.

### Additional technical details

Type	$\Delta p_v$	
<b>B6R 15 F . 30</b>	4	(3)
<b>B6R 15 F . 20</b>	4	(3)
<b>B6R 15 F . 10</b>	4	(3)
<b>B6R 15 F . 00</b>	4	(3)
<b>B6R 25 F . 10</b>	4	(2)
<b>B6R 25 F . 00</b>	4	(2)
<b>B6R 40 F . 10</b>	3	(1,5)
<b>B6R 40 F . 00</b>	3	(1,5)
<b>B6R 50 F . 00</b>	2	(1)

$\Delta p_v$  in bar = max. pressure difference across the valve in any stroke position, limited by the noise level and erosion (max. values without being limited by the force of the drive).

The values in brackets apply when used as a distributor valve.

### Technical information

- Pressure and temperature specifications
- Flow parameters
- Sauter slide rule for valve sizing
- Slide rule manual
- Technical manual 'Manipulating units'  
Parameters, Notes on installation, Control,  
Pneumatic manipulating units, General information

DIN 2401  
VDI/VDE 2173  
7 090011 003  
7 000129 003  
7 000477 003

### Additional details on accessories

**0217268/ . . .** Heating for stuffing box 15 W; housing of light metal; degree of protection IP 54; connecting cable  $3 \times 0,75 \text{ mm}^2$ , earth connection, 1 m in length, cable end sleeves.

**0360429** Sheet of 21 adhesive labels for flow change, see combinations.

**Additional details on model types**

Valve body with female thread; metallic seal; flat seal of copper at the body; stuffing-box with O-ring of ethylene-propylene.

**Material numbers as per DIN**

	<b>DIN material no.</b>	<b>DIN description</b>
Valve body	2.1096.01	G-Cu Sn 5 Zn Pb (Rg 5)
Valve seat	2.1096.01	G-Cu Sn 5 Zn Pb (Rg 5)
Spindle	1.4305	X 12 Cr Ni S 18 8
Plug	2.0402.26	Cu Zn 40 Pb 2 F43
Plug V6R 15 F.20...F.30	1.4305	X 12 Cr Ni S 18 8
Stuffing box	2.0401.10	Cu Zn 39 Pb 3 F36

**Explanation of terms used** **$\Delta p_v$ :**

Maximum permissible pressure difference across the valve in any stroke position, limited by the noise level and erosion.

The valve as a traversed element is defined by this parameter specifically in its hydraulic behaviour. By monitoring cavitation, erosion and the noise thus produced, improvements can be achieved in both life expectancy and durability.

 **$\Delta p_{max}$ :**

Maximum permissible pressure difference across the valve at which the drive can firmly open and close the valve.

Static pressure and fluidic influences are taken into account. This value helps to maintain smooth stroke action and valve sealing. In doing so, the valve's  $\Delta p_v$  value is not exceeded.

 **$\Delta p_s$ :**

Maximum permissible pressure difference across the valve in the event of a malfunction (e.g. power failure, excess temperature or pressure, burst pipe) at which the drive can firmly close the valve and, if necessary, hold the full operating pressure against atmospheric pressure. Since this is a safety function with 'fast' stroke,  $\Delta p_s$  can be larger than  $\Delta p_{max}$  or, respectively,  $\Delta p_v$ . The resultant fluidic disturbances are soon overcome and play a minor role here.

On the three-way valves, the values apply only for the control passage.

 **$\Delta p_{stat}$ :**

Line pressure behind the valve. This corresponds largely to the dead pressure when the pump is switched off, e.g. due to the level of liquid in the plant, an increase in pressure via the pressure store, steam pressure etc.

On valves that close with the pressure, the static pressure plus the pump pressure should be used.

Dimension drawings 5M100

B6R

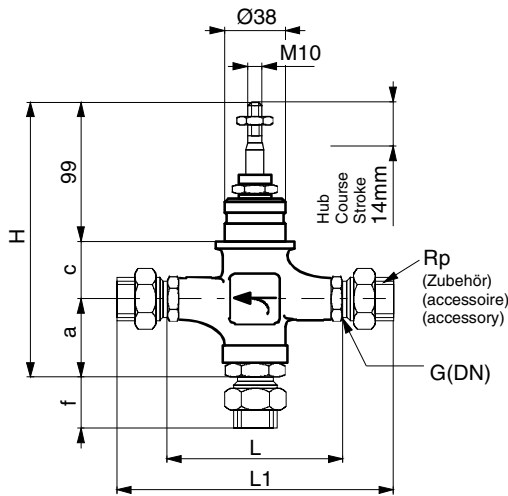

DN	a	c	f	H	L	L1	G	Rp
15	1/2"	59	29	37	187	85	159	1/2
25	1"	69	33	43	201	110	196	1
40	1 1/2"	76	47	53	222	150	256	1 1/2
50	2"	98	57	57	254	180	294	2

M361065a

AVM 2..

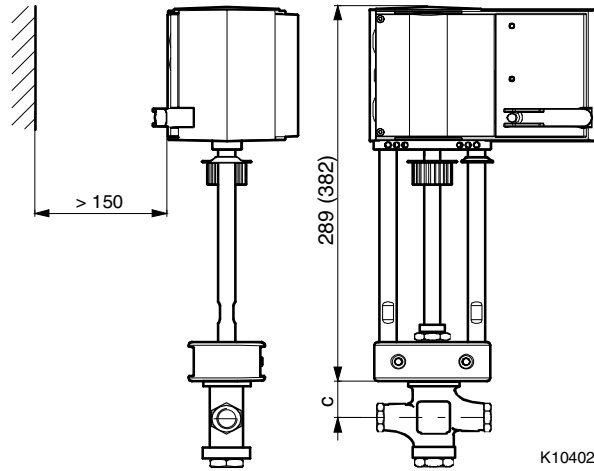

K10402

AVF 2..

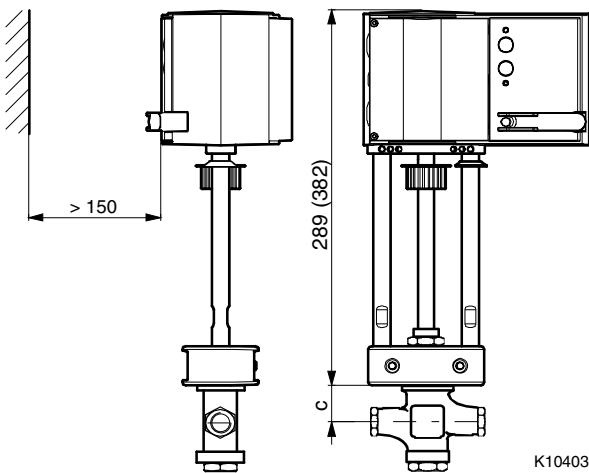

K10403

AVN 2..

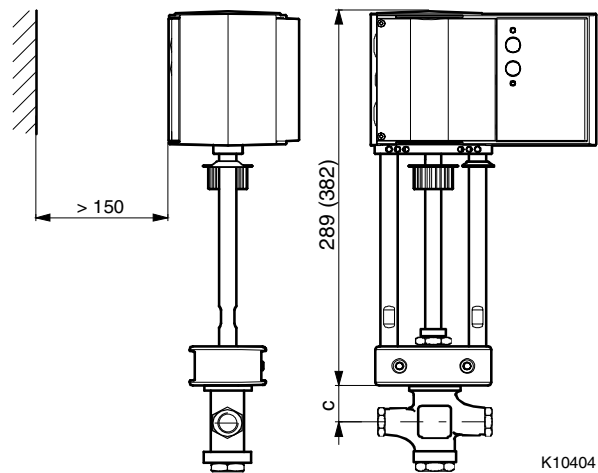

K10404

Fitting width:

Use measurement 'c' from valve dimension drawing