

## BUG: Three-way flanged valve, PN 25/16

Control valve, free of silicone grease for continuous/modulating control of cold, warm or hot water, steam, steam/water or air in HVAC plants. Water quality to VDI 2035. Together with valve drives AVM 234S, AVF 234S and AVN 224S as regulating unit. Valve tested to DIN 32730 <sup>1) 2) 3)</sup>.

Valve body made of spheroidal-graphite cast (EN-GJS-400-18-LT), painted black. Stem, valve seat and cone made of stainless steel (DN 15...50) with glass-fibre-reinforced Teflon sealing ring. Stuffing box made of brass with Teflon washer, spring-loaded. Valve characteristic equal-percentage. can be switched over to linear or quadratic with SUT valve drives. For use as a mixing and distributor valve. Used with PN 16 or PN 25 counterflanges. The control passage of the valve is closed when the stem is extended.



T10431



Y07545

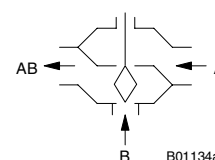

B01134a

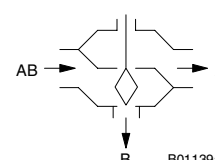

B01139a

Type	Nominal diameter DN	Connection	$k_{VS}$ value m <sup>3</sup> /h	Weight kg
BUG 015 F334	15	PN 25/16	1	3,1
BUG 015 F324	15	PN 25/16	1,6	3,1
BUG 015 F314	15	PN 25/16	2,5	3,1
BUG 015 F304	15	PN 25/16	4	3,1
BUG 020 F304	20	PN 25/16	6,3	4,0
BUG 025 F304	25	PN 25/16	10	4,7
BUG 032 F304	32	PN 25/16	16	7,2
BUG 040 F304	40	PN 25/16	25	9,2
BUG 050 F304	50	PN 25/16	40	11,9
BUG 065 F316	65	PN 16	63	26,8
BUG 065 F304	65	PN 25	63	27,1
BUG 080 F304	80	PN 25/16	100	36,3
BUG 100 F304	100	PN 25	160	53
BUG 125 F304	125	PN 25	250	79,1
BUG 150 F304	150	PN 25	340	108,7

Operating temperature <sup>1)</sup>	-20...240 °C	Valve stroke	
Operating pressure	up to 120 °C 25 bar	DN 15...50	20 mm
	up to 240 °C 20 bar	DN 65...150	40 mm
	-20...-10 °C 18 bar	Dimension drawing	
Valve characteristic for control passage	equal-percentage	DN 15...50 (65)	M10425
Valve characteristic for mixing passage	linear	DN 65...150	M10446
Rangeability	> 50:1	Installation instructions	
Stuffing box	brass / Teflon	DN 15...50	MV 505947
Leakage rate at max. $\Delta p_s$ :		DN 65...150	MV 505973
control passage	$\leq 0,05\%$ of $k_{VS}$ value	AVM 234 / assembly	MV 505919
mixing passage	$\leq 1,0\%$ of $k_{VS}$ value	AVF 234 / assembly	MV 505920
		AVN 224 / assembly	MV 505927
		Declaration on materials	MD 56.121

### Accessories

- 0372336 180\*** Intermediate piece (required for medium > 130 °C / < 180 °C; MV 505902)
- 0372336 240\*** Intermediate piece (required for medium > 180 °C / < 240 °C; MV 505902)
- 0378283 001** Replacement pack for stuffing box, nominal diameter DN 15-150; MV 505950
- 0378284 100\*** Stuffing box heater, 230 V~; 15 W, for media below 0 °C; MV 505978
- 0378284 102\*** Stuffing box heater, 24 V~; 15 W, for media below 0 °C; MV 505978
- 0378285 001** Stuffing box, stainless steel /Teflon DN 15...150
- 0378384 001** Anti-torsion device DN 65...150

<sup>\*)</sup> Dimension drawing or wiring diagram available under the same number

- 1) At temperatures below 0 °C, use the stuffing box heater; at temperatures above 130 °C or 180 °C use the appropriate intermediate piece (accessory).  
Down to -10 °C, as per AD code of practice W 10. Water with anti-frost products and brines  
For use in accordance with DIN 32730, the permissible temperature of the medium is > 0 °C.
- 2) The BUG 065 F316 valves do not have TÜV approval. They do not bear the test institute's code and are classified under Category I of the Directive on Pressure Equipment. These valves can be employed with the AVN 224S F... actuator, but not as a safety unit
- 3) DIN 32730 has been substituted by DIN EN 14597.

**Warranty** The technical data and pressure differences indicated here are only applicable in combination with Sauter valve drives. Any warranty shall lapse if valve drives from other manufacturers are used.

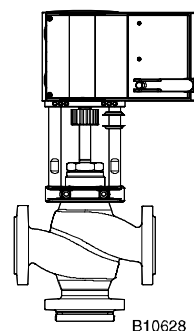
**Combination of BUG with electrical drive (combination without 230 V module or accessories)**

B10628

<b>Drive</b>	without spring return, 2500 N pushing force:					
Type:	<b>AVM 234S F132 (24 V)</b>					
Running time:	2 / 4 / 6 s/mm					
Input:	2pt / 3pt / 0...10 V / 4...20 mA					
Valve	Used as a mixing valve			Used as a distributor valve		
	$\Delta p_{\max}$	$\Delta p_s$	Close/off pressure	$\Delta p_{\max}$	$\Delta p_s$	Close/off pressure
<b>BUG 015</b>	16	–	25	6	–	25
<b>BUG 020</b>	16	–	25	6	–	25
<b>BUG 025</b>	16	–	25	6	–	25
<b>BUG 032</b>	16	–	25	6	–	24
<b>BUG 040</b>	16	–	17	6	–	15,5
<b>BUG 050</b>	11	–	11	6	–	10
<b>BUG 065</b>	7,1	–	7,1	4,5	–	6,5
<b>BUG 080</b>	4,7	–	4,7	3,5	–	4,4
<b>BUG 100</b>	3,0	–	3,0	3,0	–	2,8
<b>BUG 125</b>	2,0	–	2,0	2,0	–	2,0
<b>BUG 150</b>	1,5	–	1,5	1,0	–	1,5

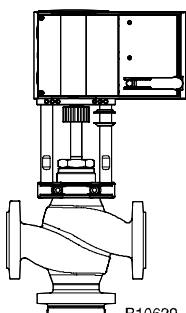

B10629

<b>Drive</b>	With spring return, 2000 N pushing force:					
Type:	<b>AVF 234S F132 (24 V)</b>					
Running time:	2 / 4 / 6 s/mm					
Input:	2pt / 3pt / 0...10 V / 4...20 mA					
Spring return:	15 ... 30 s					
Valve	Used as a mixing valve			Used as a distributor valve		
	$\Delta p_{\max}$	$\Delta p_s$	Close/off pressure	$\Delta p_{\max}$	$\Delta p_s$	Close/off pressure
<b>BUG 015</b>	16	25	25	6	25	25
<b>BUG 020</b>	16	25	25	6	25	25
<b>BUG 025</b>	16	25	25	6	25	25
<b>BUG 032</b>	16	21	21	6	25	18
<b>BUG 040</b>	13,5	13,5	13,5	6	25	12
<b>BUG 050</b>	8,5	8,5	8,5	6	25	7,5
<b>BUG 065</b>	5,6	5,6	5,6	4,5	25	5,1
<b>BUG 080</b>	3,4	3,4	3,4	3,4	25	3,4
<b>BUG 100</b>	2,2	2,2	2,2	2,2	25	2,2
<b>BUG 125</b>	1,6	1,6	1,6	1,6	25	1,6
<b>BUG 150</b>	1,2	1,2	1,2	1,0	25	1,2

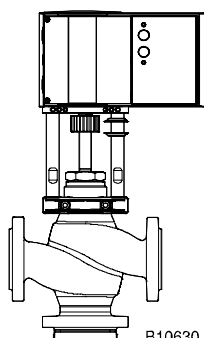

B10630

<b>Drive</b>	With emergency function to DIN 32730, 1100 N pushing force (look <sup>2</sup> ) page 1):					
Type:	<b>AVN 224S F132 (24 V)</b>					
Running time:	2 / 4 / 6 s/mm					
Input:	2pt / 3pt / 0...10 V / 4...20 mA					
Spring return:	15 ... 30 s					
Valve	Used as a mixing valve			Used as a distributor valve		
	$\Delta p_{\max}$	$\Delta p_s$	Close/off pressure	$\Delta p_{\max}$	$\Delta p_s$	Close/off pressure
<b>BUG 015</b>	16	25	25	6	25	25
<b>BUG 020</b>	16	25	25	6	25	22
<b>BUG 025</b>	16	17	17	6	25	14,5
<b>BUG 032</b>	10,5	10,5	10,5	6	25	9,4
<b>BUG 040</b>	6,5	6,5	6,5	6	25	6,5
<b>BUG 050</b>	4	4	4	4	25	4,0
<b>BUG 065</b>	3,0	3	3,0	2,6	25	2,6
<b>BUG 080</b>	2,0	2,0	2,0	1,7	25	1,7
<b>BUG 100</b>	1,1	1,1	1,1	1,1	25	1,1
<b>BUG 125</b>	0,8	0,8	0,8	0,8	25	0,8
<b>BUG 150</b>	0,6	0,6	0,6	0,6	25	0,6

Valve: Variant F, for technical data and accessories see Valve Type Table  
 Drive: Variant F, for technical data, accessories and installation position see section 51  
 Example: BUG 040 F304 / AVM 234 S F132

$\Delta p_{\max}$  [bar]= Maximum permitted pressure difference over the valve at which the drive can still reliably open and close the valve, taking account of  $\Delta p_v$ .

$\Delta p_s$  [bar]= Maximum permitted pressure difference over the valve in case of a fault (pipe break downstream of the valve) at which the drive can close the valve reliably with "fast" performance of the stroke.

Close/off pressure [bar]= Maximum possible pressure difference over the valve in control mode, at which the drive can still open and close the valve. A reduced lifetime must be expected with this mode. Cavitation, erosion and pressure surges can damage the valve. The values are only valid for the assembled combination valve fitted on the drive.

## Function

The valve can be controlled into any desired intermediate position by means of an electrical drive. If the valve stem is extended, the control passage of the valve is closed. These valves may be used as mixing valves as well as distributor valves. The direction of flow marked on the valve must be observed or a sticker must be placed over it when 'used as a distributor valve' (the sticker is on the installation instructions). Parameters related to flow mechanics conform to EN 60534.

### Used as a mixing valve

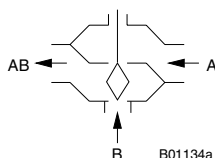

### Used as a distributor valve

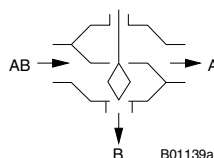

## Description

The key features of these control valves are their high reliability and precision, and they make a major contribution towards environment-friendly control. They meet demanding requirements including safety functions, coping with differential pressures, controlling the medium temperature and providing a shut-off function - and all this is achieved with a low noise level.

An automatic and fixed connection is made between the valve stem and the drive shaft. The professional Sauter cone, made of stainless steel, controls an equal-percentage flow in the control passage. To compensate for the complementary characteristic of the consumer and to guarantee an identical quantity of medium regardless of the valve position, the mixing passage acts with a linear characteristic. The tightness of this valve is guaranteed by the stainless steel ring pressed into the seat and the corresponding valve cone.

The stuffing box is maintenance-free; it consists of 6 conically shaped Teflon rings and a spring. The spring ensures constant tension in the seals, thereby guaranteeing tightness in relation to the valve stem. In addition, a grease reserve ensures constant lubrication of the valve stem. The grease reserve also prevents any particles that might be present in the medium from reaching as far as the Teflon seal.

### Engineering and installation notes

The valves are combined with the AVM 234 S valve drives without spring return action, or valve drives AVF 234 S, AVN 224 S with spring return. The drive is placed directly on top of the valve and is fixed with screws. The connection between the drive and the valve stem is made automatically. When the plant is operated for the first time, the AVM 234 S and AVF 234 S drive moves out and the lock automatically closes the connection with the valve once it has reached the lower valve seat. The valve stroke is also detected by the drive and no further adjustments are required. This means that the force on the seat is always equal and the lowest leakage rate is always guaranteed. With the SUT drives, the characteristic can be changed over to linear or quadratic as desired.

If AVN 224 S valve drives are used, the drive has to be initialised manually. For a more precise description of this, see PDS 51.379 'Initialisation and feedback signal'.

### Installation position

The final control element can be installed in any desired position, but the an installed position facing downwards is not recommended. Condensate and water drips etc. must be prevented from penetrating into the drive. With a horizontal installed position, the permitted maximum weight on the valve is 25 kg unless a support is provided by the customer or others.

**up to 130 °C:** in any position, but not facing downwards.

**above 130 °C:** at temperatures above 130 °C or 180 °C respectively, the horizontal installed position is recommended and the intermediate piece corresponding to the temperature must be inserted. However, the intermediate piece can also serve as an extension so as to bring the drive out of the pipe insulation. The pipes must be insulated to protect the valve drive against great heat.

When fitting the drive onto the valve, you must make sure that the cone is not rotated on the stainless steel seat (this would damage the sealing surfaces). If the valve is insulated, the insulation must only extend as far as the connecting clip of the drive.

### Applications with steam

The valves can be used for steam applications up to 200 °C with the same  $\Delta p_{max}$  values shown in the combination tables. However, we advise you only to use the valves for open-closed switching. For use as a control valve, you should make sure that the majority of the work is not done in the lower third of the valve stroke range. In this position, an extremely high flow speed would develop, severely reducing valve's lifetime.

**Applications with water**

To ensure that impurities in the water (such as welding beads or particles of rust, etc.) are retained and the cone seal is not damaged, it is advisable to install collective filters, e.g. for each storey or pipe run. Water quality requirements conform to VDI 2035. If an additional medium is used, the compatibility of the valve materials must be clarified with the manufacturer of the medium. The Material Table shown below can be used for this purpose. If glycol is used, we recommend that a concentration of between 20% and 55% should be selected.

The valves are not suitable for drinking water or Ex zones.

**Approval for DIN 32730**

With exception of the BUG 065 F316 the valves can be employed together with the AVN 224 S actuator with emergency function in accordance with DIN 32730.

**Other notes concerning hydraulics and noises in systems**

The valves can be used in a low-noise environment. To avoid noises, the pressure differences  $\Delta p_{\max}$  listed below should not be exceeded. These are shown as recommended values in the pressure loss table.

Pressure difference  $\Delta p_v$  is the maximum pressure that may be present on the valve, regardless of the stroke position, so that the danger of cavitation and erosion is limited. These values are independent of the drive force. Cavitation accelerates wear and causes noises. To prevent cavitation, which mainly occurs with applications involving vapour or steam, differential pressure  $\Delta p_{\max}$  should not exceed value  $\Delta p_{\text{krit}}$ :

$$\Delta p_{\text{krit}} = (p_1 - p_v) \times 0,5$$

$p_1$  = upstream pressure in front of the valve (bar)       $p_v$  = steam/vapour pressure

Absolute pressure is used for the calculations.

The close/off pressure values which are also listed represent the maximum pressures at which the drive can still use its own force to move the valve. It should be pointed out here that if these pressures are used and the pressure difference  $\Delta p_{\max}$  is exceeded, the valve may sustain damage due to cavitation and erosion. In case of a spring return function, the stated  $\Delta p_s$  values also represent the permitted differential pressure up to which the drive guarantees closure of the valve in case of an incident. As this is a safety function with 'fast' passage through the stroke (by means of the spring), this value may exceed  $\Delta p_{\max}$ .

Flow-rate chart BUG

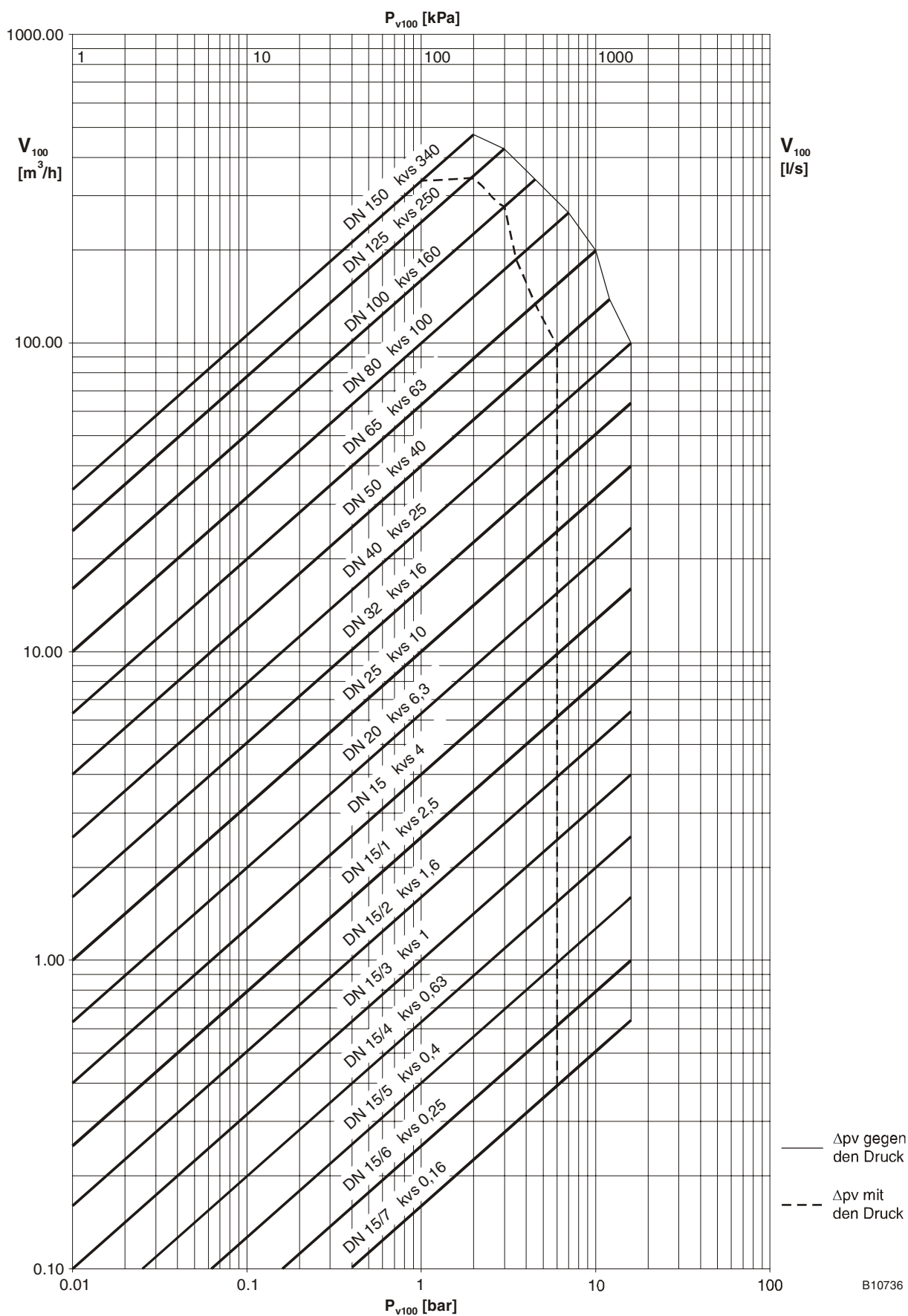

B10736

**Additional technical data**

Type	$\Delta p_v$	
	against the pressure	with the pressure
BUG 015 F334	16 bar	6 bar
BUG 015 F324	16 bar	6 bar
BUG 015 F314	16 bar	6 bar
BUG 015 F304	16 bar	6 bar
BUG 020 F304	16 bar	6 bar
BUG 025 F304	16 bar	6 bar
BUG 032 F304	16 bar	6 bar
BUG 040 F304	16 bar	6 bar
BUG 050 F304	12 bar	6 bar
BUG 065 F304	10 bar	4,5 bar
BUG 065 F316	10 bar	4,5 bar
BUG 080 F304	7 bar	3,5 bar
BUG 100 F304	4,5 bar	3 bar
BUG 125 F304	3 bar	2 bar
BUG 150 F304	2 bar	1 bar

Pressure and temperature data  
Parameters related to flow mechanics  
Sauter slide rule for valve dimensioning  
Manual for slide rule  
Technical manual: 'Regulating Units'  
Parameters, installation notes, control, general

EN 764, EN 1333  
EN 60534  
7 090011 003  
7 000129 003  
7 000477 003  
Valid EN, DIN,  
AD, TRD and UVV  
regulations  
97/23/EC  
Category I  
Category IV  
DIN 32730  
Category II

CE conformity, Pressure Equipment Directive (fluid group II)  
BUG 065 F316 CE symbol  
BUG ... with AVN 224S F132: CE-0035 symbol  
(look <sup>2</sup>) page 1)  
BUG ... without AVN 224S F132: CE-0035 symbol

**Additional information on execution**

Valve body made of spheroidal-graphite cast to EN 1563. Code EN-GJS-400-18-LT. Material number EN-JS1025 with smooth drilled flanges to EN 1092-2, form B, sealing strip. Valve body protected by matt paint to RAL 9005, dark black. Overall valve length to EN 558-1, basic series 1. Flat seal on valve body made of asbestos-free material.

**DIN material numbers**

	DIN material number	DIN designation
Valve body	EN-JS1025	EN-GJS-400-18-LT (GGG40.3)
Valve seat	1.4021	X 20 Cr 13
Stem	1.4305	X 8 Cr Ni S 18-9
Cone	1.4305	X 8 Cr Ni S 18-9
Conical seal	PTFE	glass-fibre reinforced
Stuffing box	CW 617 N	Cu Zn 40 Pb 2
Seal below stuffing box	CW024A	Cu-DHP

### Amplified information on pressure difference definitions

#### $\Delta p_v$ :

Maximum permitted pressure difference over the valve for every position of the stroke, limited by noise level and erosion.

This parameter specifically characterises the hydraulic behaviour of the valve as an element through which a flow passes. Monitoring of cavitation and erosion, and the associated development of noise, will improve the valve's lifetime as well as its usability.

#### $\Delta p_{max}$ :

Maximum permitted pressure difference over the valve at which the drive can reliably open and close the valve.

The following are taken into account: static pressure and influences related to flow mechanics. Faultless performance of the stroke and tightness are guaranteed with this value, and in no case is valve value  $\Delta p_v$  exceeded.

#### $\Delta p_s$ :

Maximum permitted pressure difference over the valve in case of a fault (such as a voltage failure, excessive increase in temperature and pressure, and pipe break) at which the drive can close the valve tightly and can hold the full operating pressure against atmospheric pressure if need be. As this is a safety function with a 'fast' performance of the stroke,  $\Delta p_s$  may be greater than  $\Delta p_{max}$  or  $\Delta p_v$ . The disruptive influences arising here in connection with flow mechanics are quickly passed through, and are of secondary importance in this functioning mode.

For three-way valves, the values only apply to the control passage.

#### $\Delta p_{stat}$ :

Pipe pressure upstream of the valve. Essentially corresponds to the dead pressure with the pump switched off, caused (for example) by the fluid level in the system, increase in pressure due to the pressure tank, steam pressure, etc.

For valves which close with the pressure, the static pressure added to the pump pressure must be used for this purpose.

### Characteristic for drives with a positioner (only 24 V)

On drive AVM 234 S. AVF 234 S or AVN 224 S

Equal-percentage / linear / quadratic

Can be set with the code switch

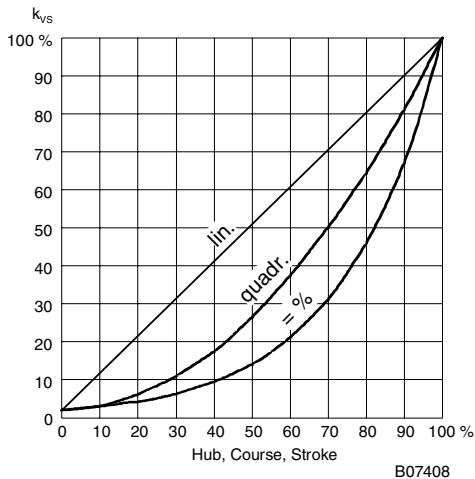

Dimension drawings

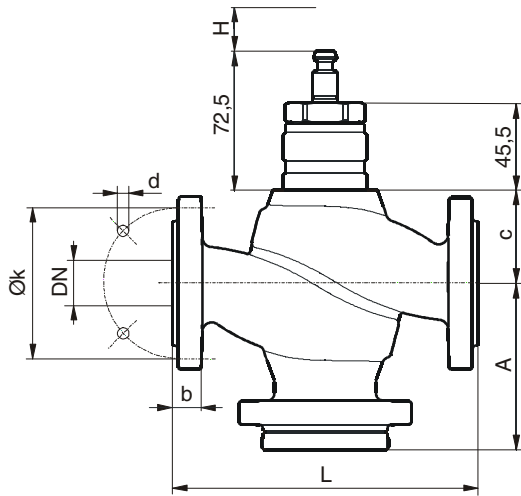

BUG	DN	A	c	L	H	k	d	b
015	15	75,5	54	130	20	65	14 x 4	14
020	20	83,5	48	150	20	75	14 x 4	16
025	25	86,5	50	160	20	85	14 x 4	16
032	32	99,5	59	180	20	100	19 x 4	18
040	40	105,5	63	200	20	110	19 x 4	19
050	50	113,5	67	230	20	125	19 x 4	19
065	65/ PN16	120,0	163	290	40	145	19 x 4	19

M10425c

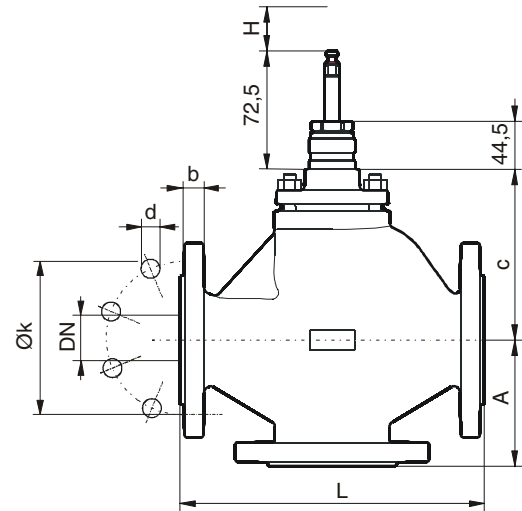

BUG	DN	A	c	L	H	k	d	b
065	65/PN25	120	163	290	40	145	19 x 8	19
080	80	130	182	310	40	160	19 x 8	19
100	100	150	183	350	40	190	23 x 8	19
125	125	200	223	400	40	220	28 x 8	19
150	150	210	257	480	40	250	28 x 8	20

M10446c

AVM

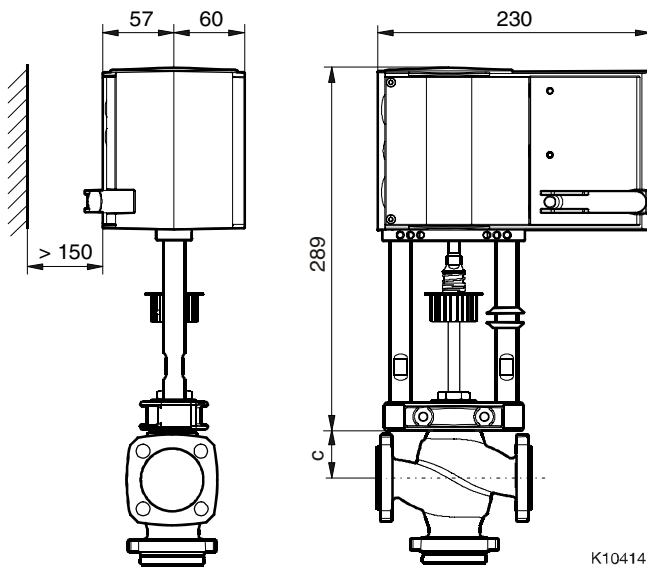

K10414

AVF

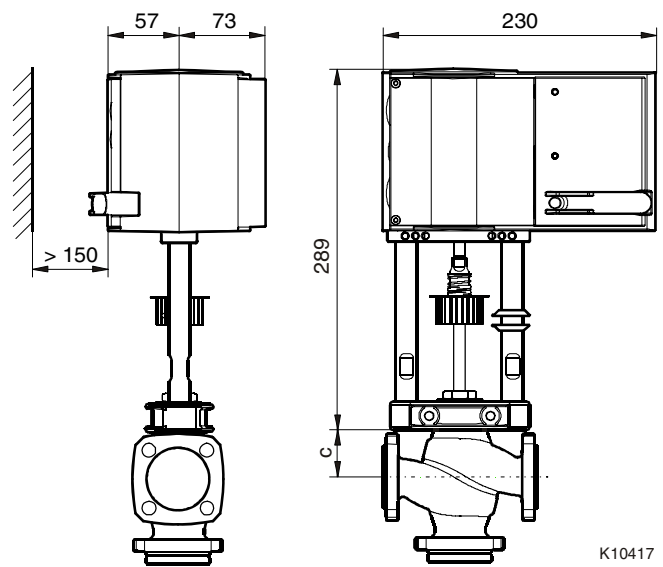

K10417

AVN

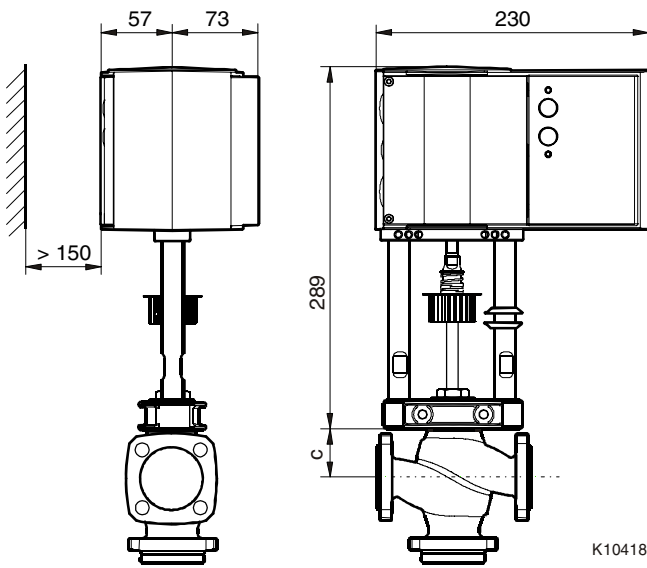

K10418

Accessories

0372336 180  
0372336 240

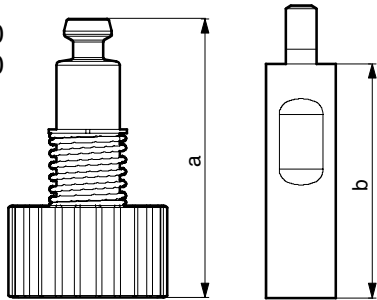

0372336	T (°C)	a (mm)	b (mm)
180	180	69,4	60
240	240	109,4	100

Z10217

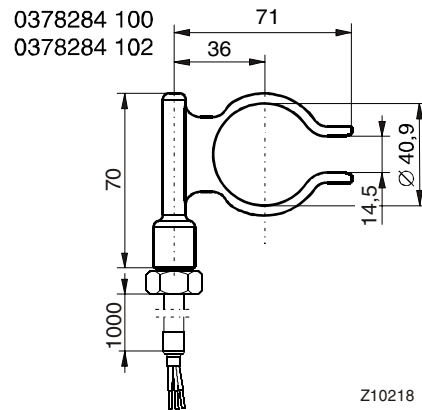

Z10218