

BUN: Three-way valve with male thread, PN 16

Usage areas

Control valve for continuous regulation of cold water, hot water or air in closed circuits ¹⁾. Water characteristics in accordance with VDI 2035. Used as an actuator in conjunction with valve drives AVM 105(S), 115(S), 124, 125S and AVF 124, 125S.

Properties

- Free of silicon grease
- Valve unit and valve seat made from dezincification-free cast brass
- Spindle made from stainless steel
- Plug made from zinc-free brass with glass fibre-reinforced Teflon sealing ring
- Characteristic curve can be set to linear, equal-percentage or quadratic with SUT valve drives
- The control passage A-AB is closed when the stem is extended

Technical description

- Valve with male thread in accordance with DIN EN ISO 228-1
- Stuffing box made from dezincification-free brass with scraper ring and double O-ring seal made from EPDM



T10640



Y07545

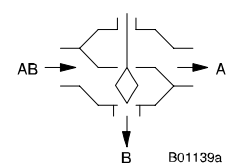
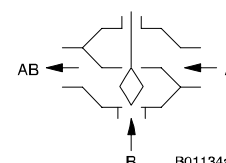

Type	Nominal Diameter DN	Connection	kvs Value m ³ /h	Weight kg
BUN 015 F350	15	G 1B	0,4	0,82
BUN 015 F340	15	G 1B	0,63	0,82
BUN 015 F330	15	G 1B	1	0,82
BUN 015 F320	15	G 1B	1,6	0,82
BUN 015 F310	15	G 1B	2,5	0,82
BUN 015 F300	15	G 1B	4	0,82
BUN 020 F300	20	G 1½B	6,3	1,00
BUN 025 F300	25	G 1½B	10	1,30
BUN 032 F300	32	G 2B	16	1,74
BUN 040 F300	40	G 2¼B	22	2,52
BUN 050 F300	50	G 2¾B	28	3,44
BUN 050 F200	50	G 2¾B	40	3,44

Operating temperature ²⁾	-15...150 °C	Dimension drawing	M10492
Operating pressure	up to 120 °C 16 bar up to 130 °C 13 bar up to 150 °C 10 bar	Installation guide	P100001118
Valve characteristic		AVM 105(S), 115(S)	MV506065
Control passage F200	linear	AVM 124	MV505809
F3 . 0	equal-percentage	AVM 125S	MV506066
Mixing passage	linear	AVF 124	MV505851
Control ratio	> 50:1 (typical)	AVF 125S	MV506067
Leakage rate		Declaration on materials and the environment	MD 56.101
Control passage	≤ 0,05% of kvs value		
Mixing passage	≤ 1% of kvs value		
Nominal stroke	8 mm		

Accessories

0361951 015*	1 screw fitting for male thread with flat seal DN 15
0361951 020*	1 screw fitting for male thread with flat seal DN 20
0361951 025*	1 screw fitting for male thread with flat seal DN 25
0361951 032*	1 screw fitting for male thread with flat seal DN 32
0361951 040*	1 screw fitting for male thread with flat seal DN 40
0361951 050*	1 screw fitting for male thread with flat seal DN 50
0372240 001*	Manual adjustment for valves with 8 mm stroke, MV 505813
0372249 001*	Temperature adapter (>100 °C up to max. 130 °C) for AVM, DN 15 to 50, MV 505932
0372249 002*	Temperature adapter (>130 °C up to max. 150 °C) for AVM, DN 15 to 50, MV 505932
0378284 100*	Stuffing box heater 230 V~; 15W, for media below 0 °C, DN 15 to 50, MV 505978
0378284 102*	Stuffing box heater 24 V~; 15W, for media below 0 °C, DN 15 to 50, MV 505978
0378368 001	Complete spare stuffing box for DN 15 to DN 50

*) Dimension drawing or connection diagram available under same number

1) See engineering and fitting notes for open circuits

2) At temperatures of less than 0 °C use temperature adapter (accessory).

BUN combination with electric drive

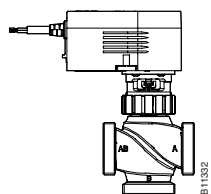

Drive	250 N pushing force					
Model:	AVM 105 F . . .		AVM 105S F . . .			
Running time:	30 s / 120 s		35 s / 60 s / 120 s			
Input:	2pt / 3pt		0...10 V			
Valve	Use as mixing valve			AVM 105 F12 .	AVM 105 F100	AVM 105S F . . .
	Δp_{max}	Δp_s	close/off pressure			
BUN 015	4	–	6			
BUN 020	4	–	4,3			
BUN 025	3	–	3			
BUN 032	2	–	2			
BUN 040	1,2	–	1,2			
BUN 050	0,8	–	0,8			

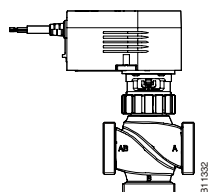

Drive	500 N pushing force							
Model:	AVM 115 F . . .		AVM 115S F . . .					
Running time:	120 s		60 s / 120 s					
Input:	2pt / 3pt		0...10 V					
Valve	Use as mixing valve			Use as distribution valve			AVM 115	AVM 115S
	Δp_{max}	Δp_s	close/off pressure	Δp_{max}	Δp_s	close/off pressure		
BUN 015	6	–	15	–	–	–		
BUN 020	5	–	9,4	–	–	–		
BUN 025	4	–	6,5	–	–	–		
BUN 032	3,7	–	4,3	–	–	–		
BUN 040	2,7	–	2,7	–	–	–		
BUN 050	1,8	–	1,8	–	–	–		

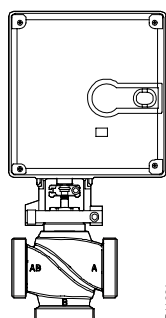

Drive	800 N pushing force							
Model:	AVM 124 F . . .		AVM 125S F . . .					
Running time:	30 s / 60 s / 120 s		30 s / 60 s / 120 s					
Input:	3pt		0...10 V or 2pt or 3pt					
Valve	Use as mixing valve			Use as distribution valve			AVM 124	AVM 125S
	Δp_{max}	Δp_s	close/off pressure	Δp_{max}	Δp_s	close/off pressure		
BUN 015	8	–	15	6	–	15		
BUN 020	8	–	10	6	–	10		
BUN 025	8	–	9	5	–	9		
BUN 032	6	–	7	4	–	7		
BUN 040	4,4	–	4,4	2,5	–	4,4		
BUN 050	3	–	3	1,5	–	3		

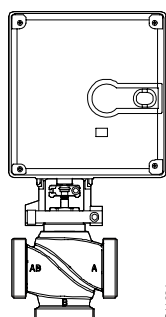

Drive	500 N pushing force							
Model:	AVF 124 F . . .		AVF 125S F . . .					
Running time:	60 s / 120 s		60 s / 120 s					
Input:	3pt		0...10 V or 2pt or 3pt					
Spring return:	18 ± 10 s		18 ± 10 s					
Valve	Use as mixing valve			Use as distribution valve			AVF 124	AVM 125S
	Δp_{max}	Δp_s	close/off pressure	Δp_{max}	Δp_s	close/off pressure		
BUN 015	6	16	16	4	16	16		
BUN 020	5	9,4	9,5	2,8	16	9,5		
BUN 025	4	6,5	6,5	2,8	16	6,5		
BUN 032	3,7	4,3	4,3	2	16	4,3		
BUN 040	2,7	2,7	2,7	1,5	16	2,7		
BUN 050	1,8	1,8	1,8	0,8	16	1,8		

Valve: F variant, see valve type table for technical data and accessories

Drive: F variant, see section 51 for technical data, accessories and installation position

Example: BUN 015 F310 / AVM 115S F132

Δp_{max} [bar] Maximum permissible pressure difference across the valve at which the drive can still reliably open and close the valve taking Δp_v into consideration.

Δp_s [bar] Maximum permissible pressure difference across the valve in the event of a problem (pipeline break downstream of valve) at which the drive can reliably close with "fast" stroke passage

close/off pressure Maximum possible pressure difference across the valve during control operation at which the drive can still open and close the valve. A shorter service life can be expected if this method is used. Cavitation, erosion and pressure surges can damage the valve. The values only apply to the assembled combination of the valve fitted to the drive.

Function

The valve can be controlled to any intermediate position using an electric drive. The valve is closed with the valve stem extended. Use as a mixing valve is possible with valve drive AVM 105(S), 115(S), 124, 125S or valve drive with spring return AVF 124, 125S. Use as a distribution valve is only permitted with AVM 124, 125S and AVF 124, 125S.

Use as mixing valve

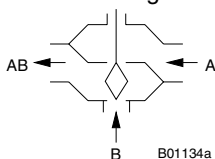

Use as distribution valve

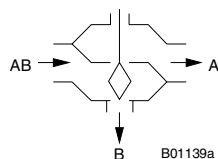

Description

These control valves are characterised by being extremely reliable and accurate, and make a considerable contribution to providing environmentally friendly control. They comply with the most demanding requirements such as having a rapid closing function, handling differential pressures, controlling media temperatures and providing a shut-off facility – all with a low-noise design.

The valve stem is automatically and firmly connected to the drive shaft. The brass plug ensures that there is an equal-percentage flow in the control passage (exception BUN 050 F200: linear flow). In order to correct the complementary characteristic curve of the consumer and provide a consistent quantity of medium regardless of the valve position, the mixing passage operates with a linear characteristic curve. This combination also eliminates plug fluttering in the final position and prevents cavitation and erosion from occurring at an early stage. Since there is no spring power to counteract the closing of the valve, the full power of the drive is available for the permissible pressure difference. The tightness of the control passage is ensured by the seat in the body and the fibre glass-reinforced Teflon seal on the plug.

The stuffing box is maintenance-free. This consists of a brass body, 2 O-rings, a scraper ring and a supply of grease. This is silicon-free, i.e. silicon oil must not be used for the stems.

Engineering and fitting notes

The valves are combined with the valve drives with or without a spring return. The drive is directly attached to the valve and secured using nut or bolts. The drive is connected to the valve stem automatically. During initial commissioning of the system the drive moves out and the lock closes automatically when it reaches the lower valve seat. The stroke of the valve is also detected by the drive, meaning that no other settings are required. The force on the seat is therefore always consistent and ensures that the leakage rate is minimal. The characteristic curve of the SUT drives can be set to linear or quadratic. The combination of the AVM 105S and the DN 50 F200 cannot be switched to equal percentage, use AVM 115S.

In order to prevent impurities from being retained in the water (e.g. welding beads, rust particles etc.) and damaging the stem seal, collective filters must be installed on each floor or in each feed pipe. For water requirements see VDI 2035.

All valves must only be used in closed circuits. Excessive oxygen content in open circuits can destroy the valve. In order to prevent this, an oxygen binding material must be used; the manufacturer of the solution must be consulted with regard to compatibility in order to prevent corrosion.

The material list can be used for this purpose.

The valves are usually insulated in the systems. Care must be taken not to insulate the collar that holds the drive when doing this. A stuffing box heater must also never be insulated.

In order to prevent interfering flow noise in quiet rooms, the pressure difference across the valve must not exceed 50% of the specified values.

The manual operation facility (accessory) is fitted to the valve like a drive. The connection to the valve stem takes place automatically when the valve is opened with the knob.

Use with water

When water that has been mixed with glycol or inhibitor is being used, compatibility with the materials and seals in the valve should be clarified with the manufacturer for safety reasons. The table of materials shown below can be used for this purpose. We recommend using a concentration of between 20% and 55% when glycol is being used.

The valves are not suitable for use in potentially explosive areas. The materials that have been selected are approved for use with drinking water. The entire valve as a unit is not certified for use with drinking water.

Installation position

The final control element can be installed in any position, but a suspended installation position is not recommended. Condensation and dripping water must be prevented from penetrating the drive.

Flow-rate chart

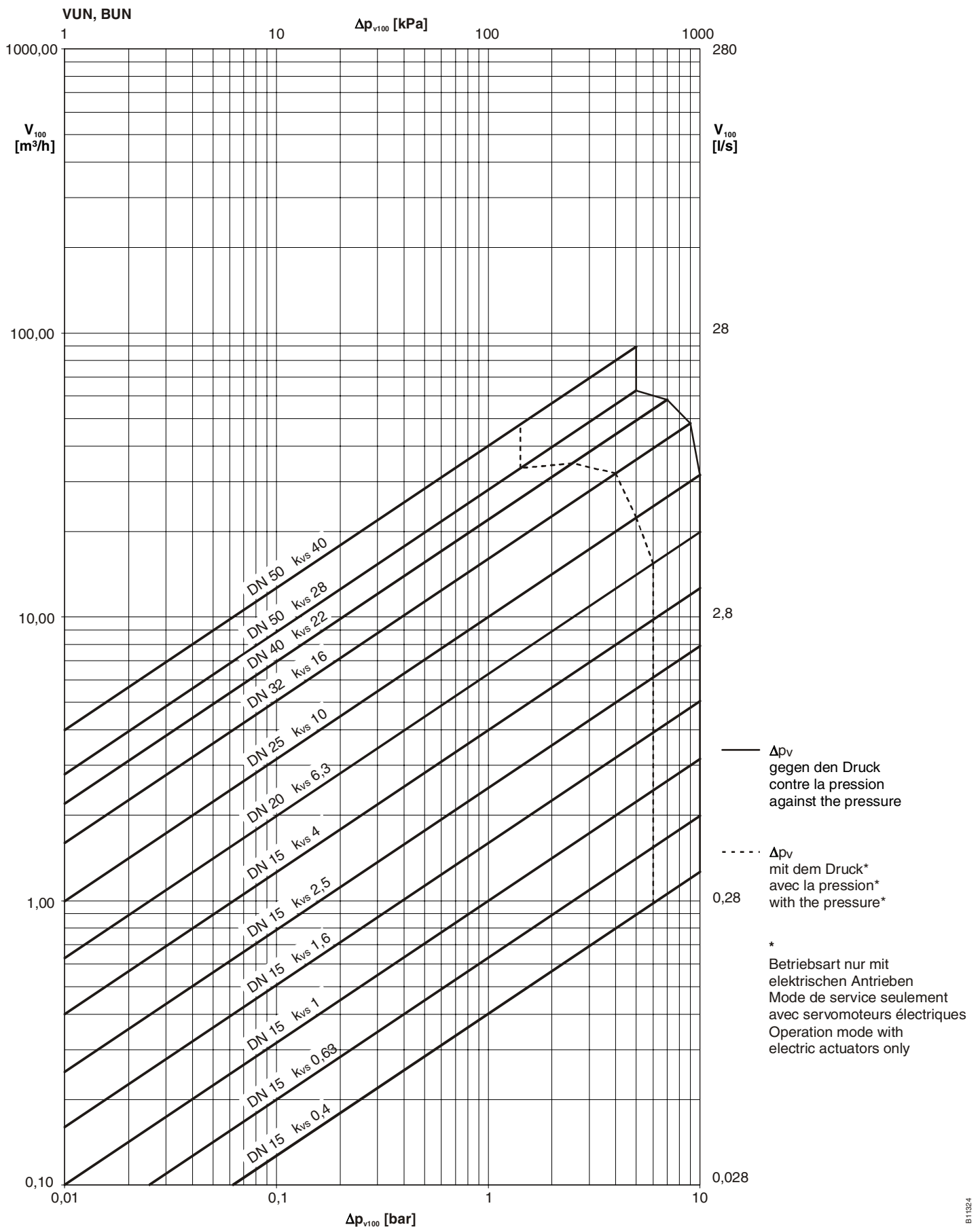

Type	Δp_v	
	Use as mixing valve	Use as distribution valve
BUN 015 F350	10	6
BUN 015 F340	10	6
BUN 015 F330	10	6
BUN 015 F320	10	6
BUN 015 F310	10	6
BUN 015 F300	10	6
BUN 020 F300	10	6
BUN 025 F300	10	5
BUN 032 F300	9	4
BUN 040 F300	7	2,5
BUN 050 F300	5	1,5
BUN 050 F200	5	1,5

Additional technical data

Technical Information

Pressure and temperature specifications

Fluidic parameters

Sauter slide rule for valve dimensioning

Slide rule manual

Technical handbook "Actuators"

Parameters, installation instructions, control, general

EN 764, EN 1333

EN 60534 Page 3

7 090011 003

7 000129 003

7 000477 003

Applicable EN, DIN, AD,
TRD and UVV instructions
97/23/EC article 3.3

Pressurised equipment CE conformity directive, no CE symbol (fluid group II)

Additional design specifications

Valve body made from dezincification-free chilled casting (EN 1982) with male thread, cylindrical in accordance with ISO 228/1 class B, flat seal on body. Stuffing box with double ethylene propylene O-ring.

DIN material numbers

	DIN material number	DIN designation
Valve body	CC752S-GM	Cu Zn 35 Pb 2 Al-C
Valve seat	CC752S-GM	Cu Zn 35 Pb 2 Al-C
Spindle	1.4305	X 8 Cr Ni S 18-9 + 1G
Plug	CW 602 N	Cu Zn 36 Pb 2 As
Plug seal	PTFE	
Stuffing box	CW 602 N	Cu Zn 36 Pb2 As

Supplementary information concerning pressure difference definitions

Δp_v :

Maximum permissible pressure difference across the valve in any stroke position, limited by the noise level and erosion.

The valve as a traversed element is defined by this parameter specifically in its hydraulic behaviour. By monitoring cavitation, erosion and the noise thus produced, improvements can be achieved in both life expectancy and durability.

Δp_{max} :

Maximum permissible pressure difference across the valve at which the drive can firmly open and close the valve.

Static pressure and fluidic influences are taken into account. This value helps to maintain a smooth stroke action and the high level of sealing. In doing so, the valve's Δp_v value is never exceeded.

Δp_s :

Maximum permissible pressure difference across the valve in the event of a malfunction (e.g. power failure, excess temperature or pressure, burst pipe) at which the drive can firmly close the valve and, if necessary, hold the full operating pressure against atmospheric pressure. Since this is a quick-close functions with 'fast' stroke, Δp_s can be larger than Δp_{max} or, respectively, Δp_v . The resultant fluidic disturbances are soon overcome and play a minor role here.

On the three-way valves, the values apply only for the control passage.

Δp_{stat} :

Line pressure behind the valve. This corresponds largely to the dead pressure when the pump is switched off, e.g. due to the level of liquid in the installation, an increase in pressure via the pressure store, steam pressure etc.

For valves that close with the pressure, the static pressure plus the pump pressure should be used.

Characteristic for drives with positioners

On drive AVM 105S or AVM 115S

Equal percentage / linear

On drive AVM 125S or AVF 125S

Equal-percentage / linear / quadratic

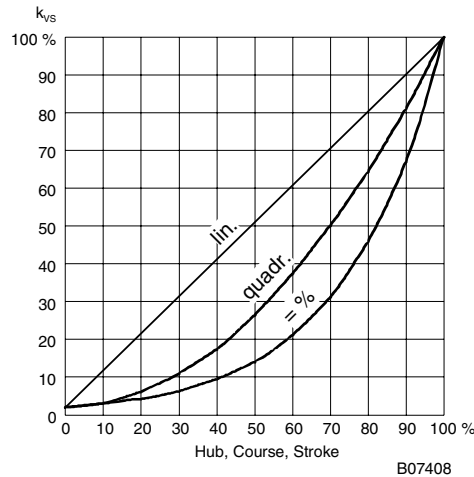

Dimension drawings

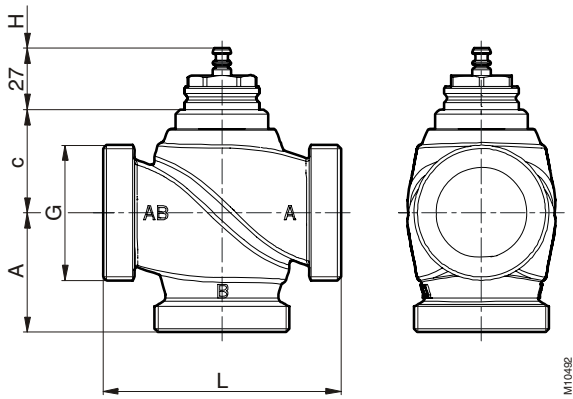

DN	A	c	L	H	G
15	50,0	45,5	100	8	G 1"
20	50,0	38,5	100	8	G 1¼"
25	52,5	42,5	105	8	G 1½"
32	52,5	45,5	105	8	G 2"
40	65,0	59,0	130	8	G 2¼"
50	75,0	67,5	130	8	G 2¾"

Combinations

AVM 105(S), 115(S)

AVM, AVF 124, 125S

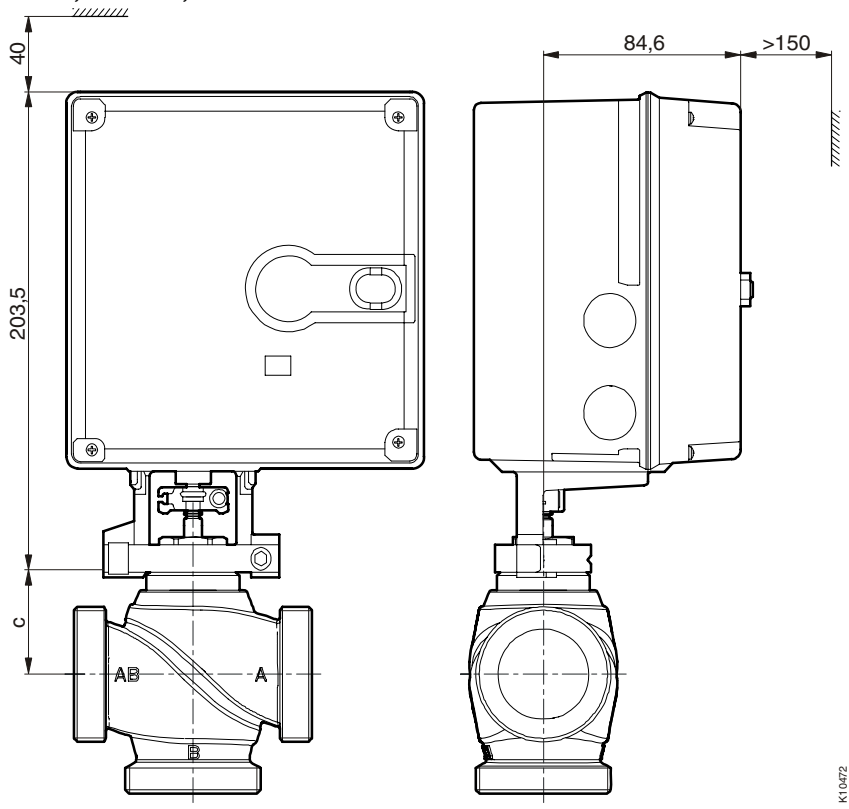
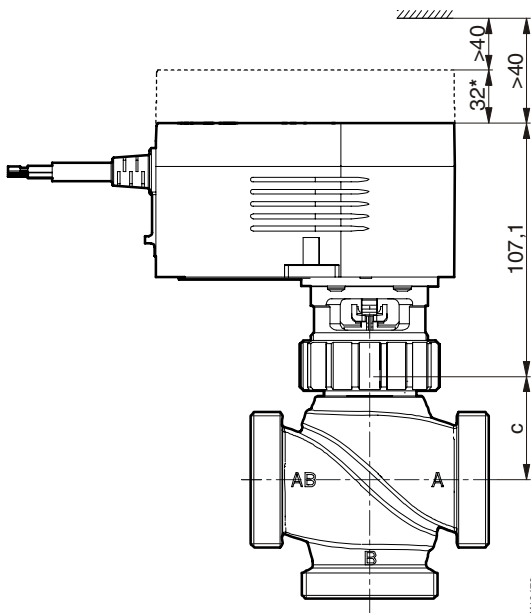

* with accessory 372145, 372286

Accessories

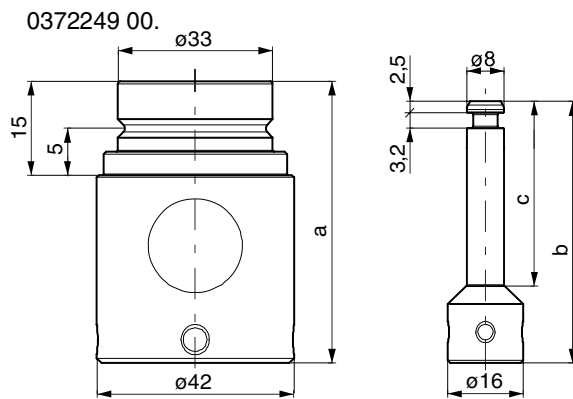
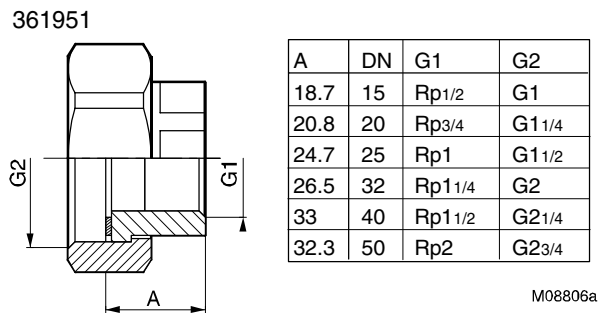
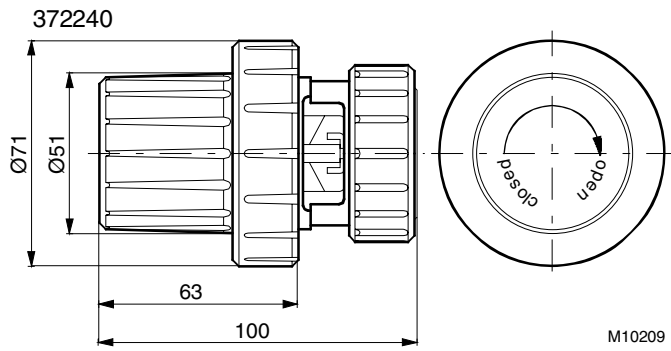

	a [mm]	b [mm]	c [mm]
0372249 001	60	55,8	40
0372249 002	80	75,8	60

Z10220

