

VUD: Through flanged valve, PN 6

Control valve, free of silicone grease for continuous/modulating control of cold water, hot water or air ¹⁾. Water quality according to VDI 2035. Together with valve drives AVM 105, AVM 115, AVM 124/ 125S, AVF 124/125, AVM/AVF 234 S and AVN 224 S as regulating unit.

Valve body and seat made of grey cast iron (EN-GJL-250), valve seat made of grey cast iron, valve stem made of stainless steel and valve cone made of brass, with glass-fibre-reinforced Teflon sealing ring for DN 15 to DN 50, and metal-to-metal sealing for DN 65 to DN 100. Stuffing box made of brass with wiper ring and double O-ring seal made of EPDM. Valve characteristic can be set as equal-percentage, linear or quadratic with SUT valve drives. The valve is closed when the stem is extended.



T10462



Y07544

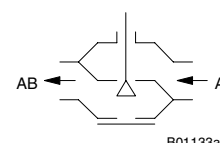

B01133a

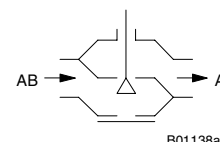

B01138a

Type	Nominal diameter DN	Connection	k_{VS} value m^3/h	Weight kg
VUD 015 F320	15	PN 6	1,6	3,2
VUD 015 F310	15	PN 6	2,5	3,2
VUD 015 F300	15	PN 6	4,0	3,2
VUD 020 F300	20	PN 6	6,3	4,1
VUD 025 F300	25	PN 6	10	4,7
VUD 032 F300	32	PN 6	16	7,3
VUD 040 F300	40	PN 6	22	8,6
VUD 050 F300	50	PN 6	28	11,2
VUD 050 F200	50	PN 6	40	11,2
VUD 065 F300	65	PN 6	49	11,9
VUD 065 F200	65	PN 6	63	11,9
VUD 080 F300	80	PN 6	78	17,7
VUD 080 F200	80	PN 6	100	17,7
VUD 100 F300	100	PN 6	124	26,0
VUD 100 F200	100	PN 6	160	26,0

Operating temperature	-10...150 °C ²⁾	Dimension drawing	
Operating pressure	6 bar	DN 15...50	M10470
Valve characteristic F200	linear	DN 65...100	M10438
Valve characteristic F300	equal-percentage	Installation instructions	
Valve rangeability	> 50:1	DN 15...50	MV 506008
Stuffing box	2-O-rings, EPDM	DN 65...100	MV 505964
Leakage rate at max. Δp_s	$\leq 0,05\%$ of k_{VS} value	AVM 104S, 114S	MV 505790
Valve stroke DN 15...50	8 mm	AVM 105, 115, 105S, 115S	MV 506065
Valve stroke DN 65...80	20 mm	AVM 124, 124S	MV 505809
Valve stroke DN 100	40 mm	AVM 125S	MV 506066
		AVF 124, 124S	MV 505851
		AVF 125S	MV 506067
		AVM 234 assembly	MV 505919
		AVF 234 assembly	MV 505920
		Declaration on materials	MD 56.110

Accessories

- [0372240 001*](#) Manual adjustment for valves with stroke of 8 mm; MV 505813
- [0372249 001*](#) Temperature adapter (>100 up to max.130 °C) for AVM, DN 15...50, MV 505932
- [0372249 002*](#) Temperature adapter (>130 up to max.150 °C) for AVM, DN 15...50, MV 505932
- [0378284 100*](#) Stuffing box heater, 230 V~; 15 W, for media below 0 °C, DN 15...100, MV 505978
- [0378284 102*](#) Stuffing box heater, 24 V~; 15 W, for media below 0 °C, DN 15...100, MV 505978
- [0378368 001](#) Complete replacement stuffing box for DN 15 to DN 50
- [0378369 001](#) Complete replacement stuffing box for DN 65 to DN 100

^{*)} Dimension drawing or wiring diagram available under the same number

1) Air humidity must not exceed 75%

2) At temperatures below 0 °C, use the stuffing box heater; at temperatures above 100 °C, use the temperature adapter (accessory).

Warranty The technical data and pressure differences indicated here are only applicable in combination with Sauter valve drives. Any warranty shall lapse if valve drives from other manufacturers are used.

Combination of VUD with electrical drive

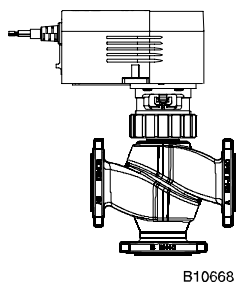

B10668

Drive	250 N pushing force					
Type:	AVM 105 F . . .		AVM 105 S F . . .			
Running time:	30 s / 120 s		35 s / 60 s / 120 s			
Input:	2pt / 3pt		0...10 V			
Valve	Against the pressure			AVM 105 F12 .	AVM 105 F100	AVM 105S F . . .
	Δp_{max}	Δp_s	Close/off pressure			
VUD 015	4	–	6			
VUD 020	4	–	4,3			
VUD 025	2,8	–	2,8			
VUD 032	2,1	–	2,1			
VUD 040	1,2	–	1,2			
VUD 050	0,9	–	0,9			

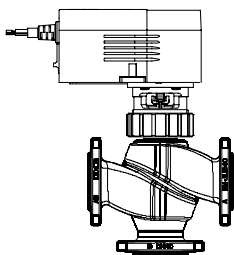

B10668

Drive	500 N pushing force							
Type:	AVM 115 F . . .		AVM 115 S F . . .					
Running time:	120 s		60 s / 120 s					
Input:	2pt / 3pt		0...10 V					
Valve	Against the pressure			With the pressure			AVM 115	AVM 115 S
	Δp_{max}	Δp_s	Close/off pressure	Δp_{max}	Δp_s	Close/off pressure		
VUD 015	6	–	6	–	–	–		
VUD 020	6	–	6	–	–	–		
VUD 025	6	–	6	–	–	–		
VUD 032	5,2	–	5,2	–	–	–		
VUD 040	3,3	–	3,3	–	–	–		
VUD 050	2	–	2	–	–	–		

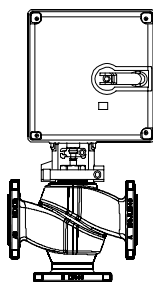

B10669

Drive	800 N pushing force							
Type:	AVM 124 F . . .		AVM 125 S F . . .					
Running time:	30 s / 60 s / 120 s		30 s / 60 s / 120 s					
Input:	3pt		0...10 V or 2pt or 3pt					
Valve	Against the pressure			With the pressure			AVM 124	AVM 125 S
	Δp_{max}	Δp_s	Close/off pressure	Δp_{max}	Δp_s	Close/off pressure		
VUD 015	6	–	6	6	–	6		
VUD 020	6	–	6	6	–	6		
VUD 025	6	–	6	5	–	6		
VUD 032	6	–	6	4	–	6		
VUD 040	5,7	–	5,7	2,5	–	5,3		
VUD 050	3,4	–	3,4	1,5	–	3,2		

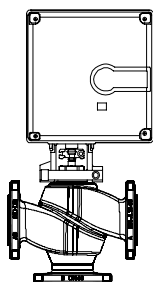

B10670

Drive	500 N pushing force							
Type:	AVF 124 F . . .		AVF 125S F . . .					
Running time:	60 s / 120 s		60 s / 120 s					
Input:	3pt		0...10 V or 2pt or 3pt					
Spring return:	18 ± 10 s		18 ± 10 s					
Valve	Against the pressure			With the pressure			AVF 124	AVF 125 S
	Δp_{max}	Δp_s	Close/off pressure	Δp_{max}	Δp_s	Close/off pressure		
VUD 015	6	6	6	6	6	6		
VUD 020	6	6	6	6	6	6		
VUD 025	6	6	6	5	6	6		
VUD 032	5,2	5,2	5,2	4	6	5,1		
VUD 040	3,3	3,3	3,3	2,5	6	3,1		
VUD 050	2,0	2,0	2,0	1,5	6	1,9		

Drive Type: Running time: Input:	2500 N pushing force AVM 234S F . . . (24 V) 2/4/6 s/mm 2pt/ 3pt/ 0...10V / 4...20 mA							
Valve	Against the pressure			With the pressure			—	AVM 234S
	Δp_{max}	Δp_s	Close/off pressure	Δp_{max}	Δp_s	Close/off pressure		
VUD 065	3	—	6	—	—	—		
VUD 080	3	—	4,4	—	—	—		
VUD 100	2	—	2,8	—	—	—		

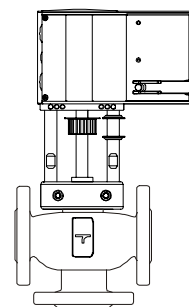

B10671

Drive Type: Running time: Input: Spring return:	2000 N pushing force AVF 234S F . . . (24 V) 2 / 4 / 6 s/mm 2pt / 3pt / 0...10V / 4...20 mA 15...30 s							
Valve	Against the pressure			With the pressure			—	AVF 234S
	Δp_{max}	Δp_s	Close/off pressure	Δp_{max}	Δp_s	Close/off pressure		
VUD 065	3	5,1	5,1	—	—	—		
VUD 080	3	3,4	3,4	—	—	—		
VUD 100	2	2,2	2,2	—	—	—		

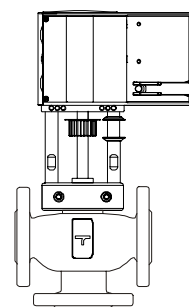

B10672

Valve: Variant F, for technical data and accessories see Valve Type Table
 Drive: Variant F, for technical data, accessories and installation position see section 51
 Example: VUD 065 F300 / AVM 234 S F132

Δp_{max} [bar]= Maximum permitted pressure difference over the valve at which the drive can still reliably open and close the valve, taking account of Δp_v .
 Δp_s [bar]= Maximum permitted pressure difference over the valve in case of a fault (pipe break downstream of the valve) at which the drive can close the valve reliably with "fast" performance of the stroke.
 Close/off pressure [bar]= Maximum possible pressure difference over the valve in control mode, at which the drive can still open and close the valve. A reduced lifetime must be expected with this mode. Cavitation, erosion and pressure surges can damage the valve. The values are only valid for the assembled combination valve fitted on the drive.

Function

The valve can be controlled into any desired intermediate position by means of an electrical drive. If the valve stem is pulled out, the control passage of the valve is closed. Valves with nominal diameters DN 15 to DN 50 may be deployed using closing procedures "against the pressure" and "with the pressure". Nominal diameters DN 65 to DN 100 may only be used with a closing procedure 'against the pressure'. The direction of flow marked on the valve must be observed, or covered with a sticker if used 'with the pressure'. Parameters related to flow mechanics conform to EN 60534.

Closing procedure against the pressure

Closing procedure with the pressure

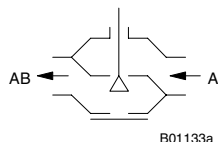

B01133a

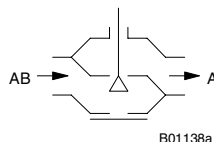

B01138a

Description

The key features of these control valves are their high reliability and precision, and they make a major contribution towards environment-friendly control. They meet demanding requirements including quick-close functions, coping with differential pressures, controlling the medium temperature and providing a shut-off function - and all this is achieved with a low noise level.

An automatic and fixed connection is made between the valve stem and the drive shaft. The cone (which is made of brass) controls an equal-percentage flow in the control passage. The tightness of this valve is guaranteed by the seat which is machined in the body.

The stuffing box is maintenance-free; it consists of a brass body, 2 O-rings, a wiper ring and the grease reserve. This is free of silicone grease and no silicone oil must be used for the stem.

Engineering and installation notes

The valves are combined with valve drives without spring return action, or valve drives with spring return action. The drive is placed directly on top of the valve and is fixed either with a nut or with screws. The connection between the drive and the valve stem is made automatically. When the plant is operated for the first time, the drive moves out and the lock closes automatically once it has reached the lower valve seat. The valve stroke is also detected by the drive and no further adjustments are required. This means that the force on the seat is always equal and the lowest leakage rate is always guaranteed. With the SUT drives, the characteristic can be changed over to linear or quadratic as desired. For the combination AVM 105S with DN50 F200 it is not possible to change the character from linear to equal-percentage.

Installation position

The final control element can be installed in any desired position, but the an installed position facing downwards is not recommended. Condensate and water drips etc. must be prevented from penetrating into the drive. With nominal diameters DN 65 to DN 100 in a horizontal installed position and in relation to the valve stem, the permitted maximum drive (or other) weight is 25 kg unless a support is provided by the customer or others.

When fitting the drive onto the valve, you must make sure that the cone is not rotated on the seat (this would damage the sealing surface). If the valve is insulated, the insulation must only extend as far as the connecting clip of the drive.

Applications with steam

The valves must not be used for applications involving steam.

Applications with water

To ensure that impurities in the water (such as welding beads or particles of rust, etc.) are retained and the stem seal is not damaged, it is advisable to install collective filters, e.g. for each storey or pipe run. Water quality requirements conform to VDI 2035.

If an additional medium is used, the compatibility of the materials must be clarified with the manufacturer of the medium. The Material Table shown below can be used for this purpose. If glycol is used, we recommend that a concentration of between 20% and 55% should be selected.

The valves are not suitable for drinking water or Ex zones.

Other notes concerning hydraulics and noises in systems

The valves can be used in a low-noise environment. To avoid noises, the pressure differences Δp_{\max} listed below should not be exceeded.

The close/off pressure values which are also listed represent the maximum pressures at which the drive can still use its own force to move the valve. It should be pointed out here that if these pressures are used and the pressure difference Δp_{\max} is exceeded, the valve may sustain damage due to cavitation and erosion. In case of a spring return function, the stated Δp_s values also represent the permitted differential pressure up to which the drive guarantees closure of the valve in case of an incident. As this is a quick-close function with 'fast' passage through the stroke (by means of the spring), this value may exceed Δp_{\max} .

Pressure loss table

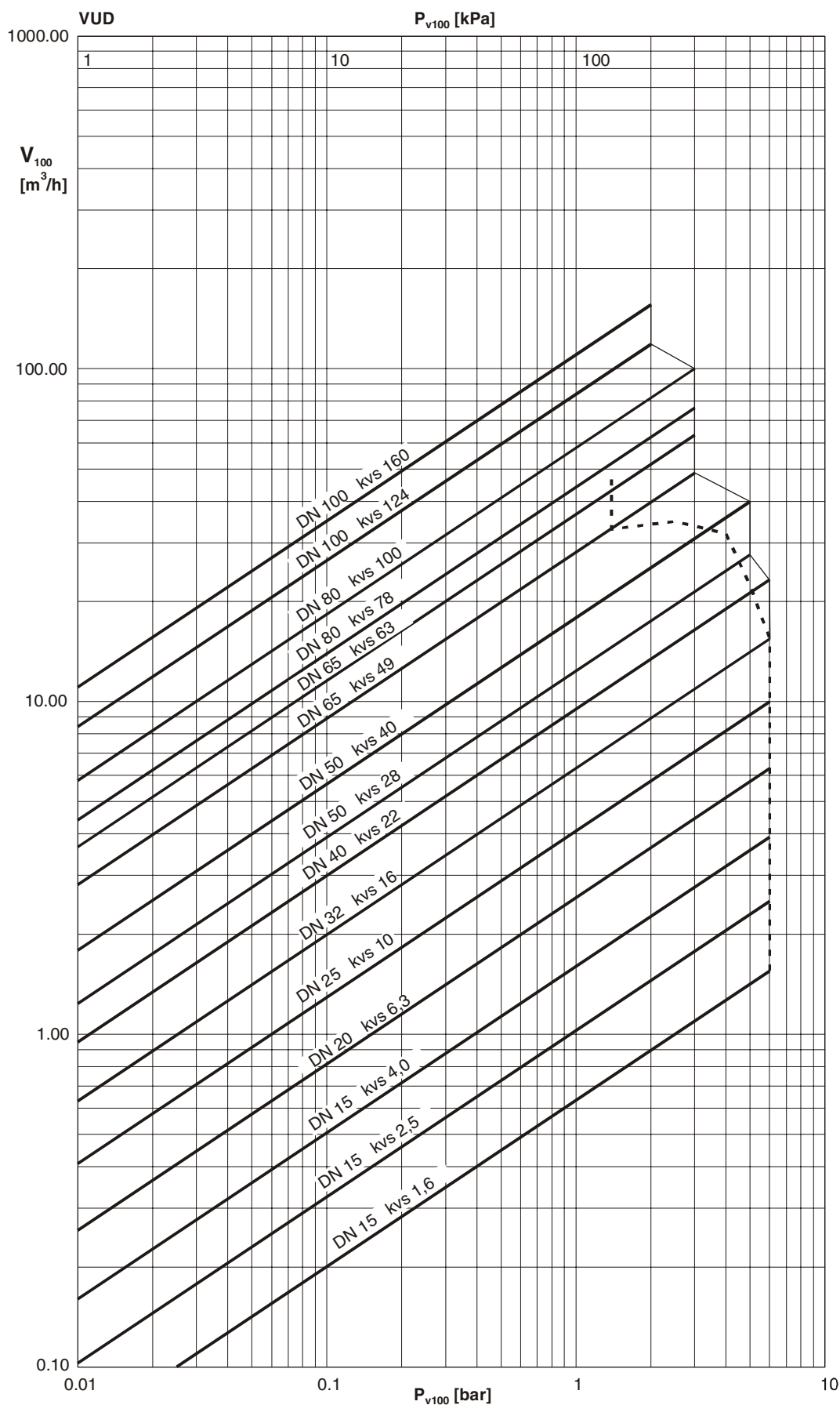

— Δp_v
 gegen den Druck
 contre la pression
 against the pressure

- - - Δp_v
 mit dem Druck*
 avec la pression*
 with the pressure*

*
 Betriebsart nur mit
 elektrischen Antrieben
 Mode de service seulement
 avec servomoteurs électriques
 Operation mode with
 electric actuators only

Type	Δp_v	
	Against the pressure	With the pressure
VUD 015 F320	6	6
VUD 015 F310	6	6
VUD 015 F300	6	6
VUD 020 F300	6	6
VUD 025 F300	6	5
VUD 032 F300	6	4
VUD 040 F300	6	2,5
VUD 050 F...	5	1,5
VUD 065 F...	3	–
VUD 080 F...	3	–
VUD 100 F...	2	–

Additional technical data

- Pressure and temperature data	EN 764, EN 1333
- Parameters related to flow mechanics	EN 60534 page 3
- Sauter slide rule for valve dimensioning	7 090011 001
- Manual for slide rule	7 000129 001
- Technical manual: 'Regulating Units'	7 000477 001
- Parameters, installation notes, control, general	Valid EN, DIN, AD, TRD and UVV specifications/regulations
- CE conformity, Pressure Equipment Directive (fluid group II)	97/23/EC
- VUD 015 to VUD 100: no CE symbol	Article 3.3

Additional information on execution

Valve body made of grey cast iron to EN 1561, code EN-GJL-250, material number EN-JL 1040 with smooth drilled flanges to EN 1092-2, form B, sealing strip. Valve body protected by matt paint to RAL 9005, dark black. Recommendation for welding-neck flange as per EN 1092-1. Overall valve length to EN 558-1, basic series 1. Flat seal on valve body made of asbestos-free material.

DIN material numbers

	DIN material number	DIN designation
Valve body	EN-JL 1040	EN-GJL-250 (GG25)
Valve seat	EN-JL 1040	EN-GJL-250
Stem	1.4305	X 8 Cr Ni S 18-9
Cone	CW 617 W	CuZn40Pb2
Conical seal	PTFE	
Stuffing box	CW 617 W	CuZn40Pb2

Amplified information on pressure difference definitions

Δp_v :

Maximum permitted pressure difference over the valve for every position of the stroke, limited by noise level and erosion.

This parameter specifically characterises the hydraulic behaviour of the valve as an element through which a flow passes. Monitoring of cavitation and erosion, and the associated development of noise, will improve the valve's lifetime as well as its usability.

Δp_{max} :

Maximum permitted pressure difference over the valve at which the drive can reliably open and close the valve.

The following are taken into account: static pressure and influences related to flow mechanics. Faultless performance of the stroke and tightness are guaranteed with this value, and in no case is valve value Δp_v exceeded.

Δp_s :

Maximum permitted pressure difference over the valve in case of a fault (such as a voltage failure, excessive increase in temperature and pressure, and pipe break) at which the drive can close the valve tightly and can hold the full operating pressure against atmospheric pressure if need be. As this is a quick-close function with a 'fast' performance of the stroke, Δp_s may be greater than Δp_{max} or Δp_v . The disruptive influences arising here in connection with flow mechanics are quickly passed through, and are of secondary importance in this functioning mode.

For three-way valves, the values only apply to the control passage.

Δp_{stat} :

Pipe pressure upstream of the valve. Essentially corresponds to the dead pressure with the pump switched off, caused (for example) by the fluid level in the system, increase in pressure due to the pressure tank, steam pressure, etc.

For valves which close with the pressure, the static pressure added to the pump pressure must be used for this purpose.

Characteristic for drives with a positioner

On drive AVM 105S or AVM 115S

Equal-percentage / linear

On drives AVM 125S, AVF 125S, AVM 234S or AVF 234S

Equal-percentage / linear / quadratic

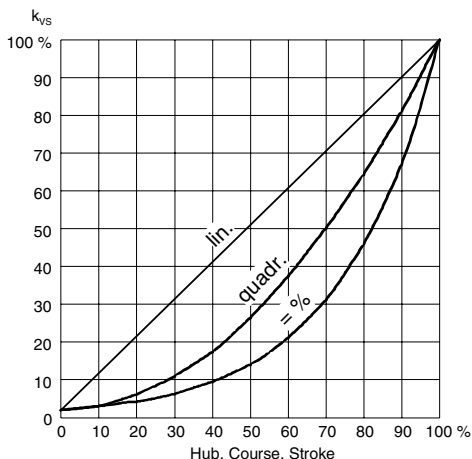

Dimension drawings

DN 15...50

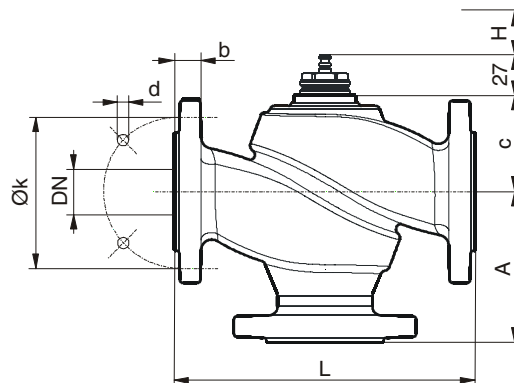

VUD, BUD	DN	A	c	L	H	k	d	b
015	15	70	41,5	130	8	55	11 x 4	14
020	20	75	48	150	8	65	11 x 4	16
025	25	80	54,5	160	8	75	11 x 4	16
032	32	95	60,5	180	8	90	14 x 4	18
040	40	100	70,5	200	8	100	14 x 4	18
050	50	115	71	230	8	110	14 x 4	20

M10470

DN65...100

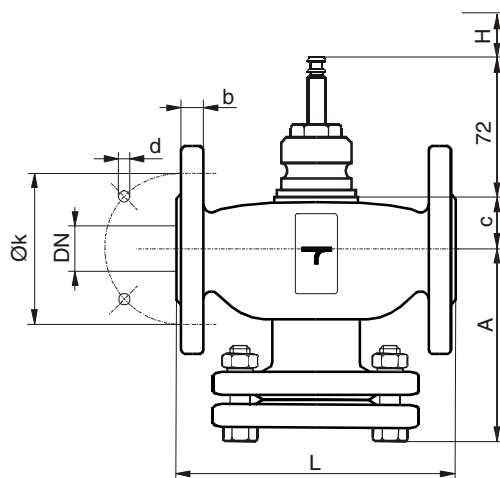

VUD	DN	A	c	L	H	k	d	b
065	65	142	62	240	20	130	14 x 4	16
080	80	156	62	260	20	150	19 x 4	18
100	100	176	93	300	40	170	19 x 4	18

M10438c

AVM 104 / 105 / 114 / 115 / S

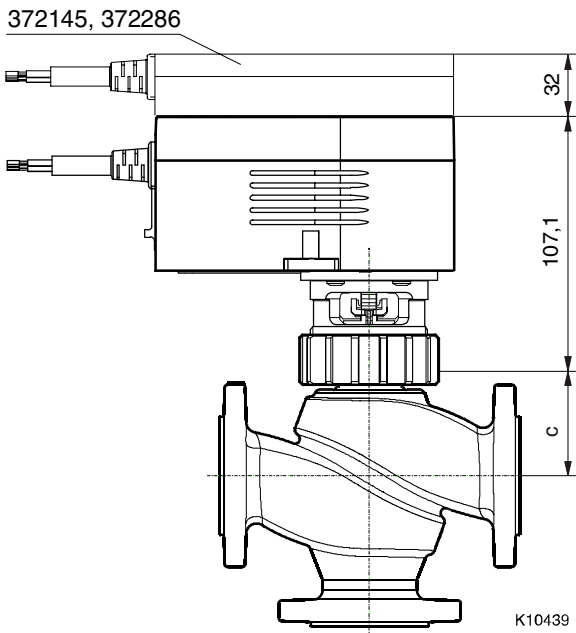

AVM / AVF / 124 / 125 / S

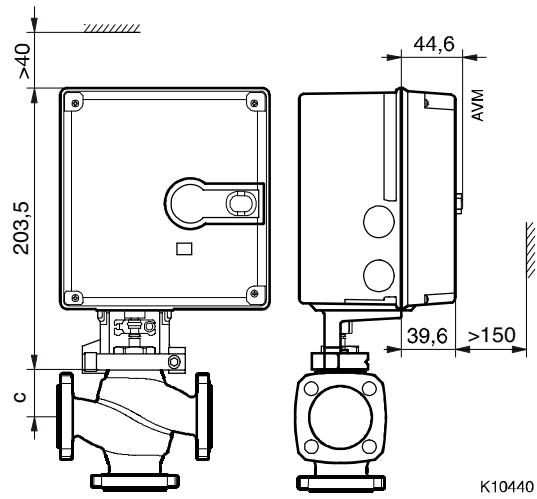

AVM 234

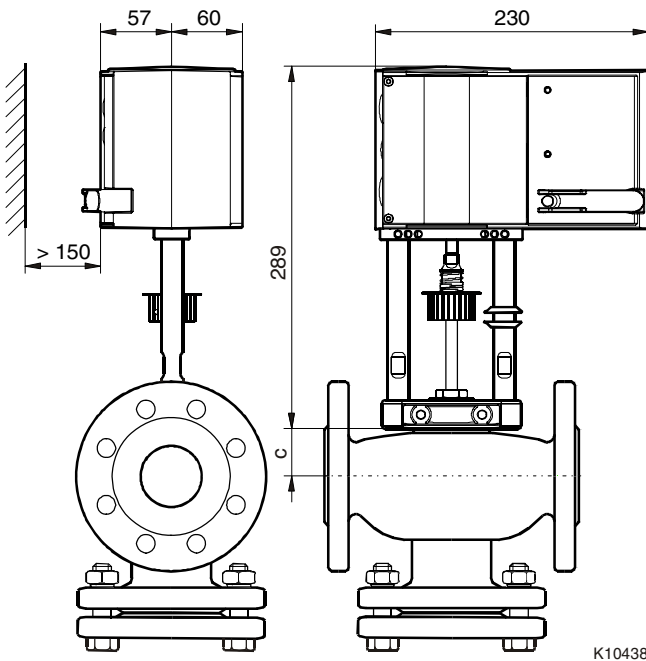

AVF 234

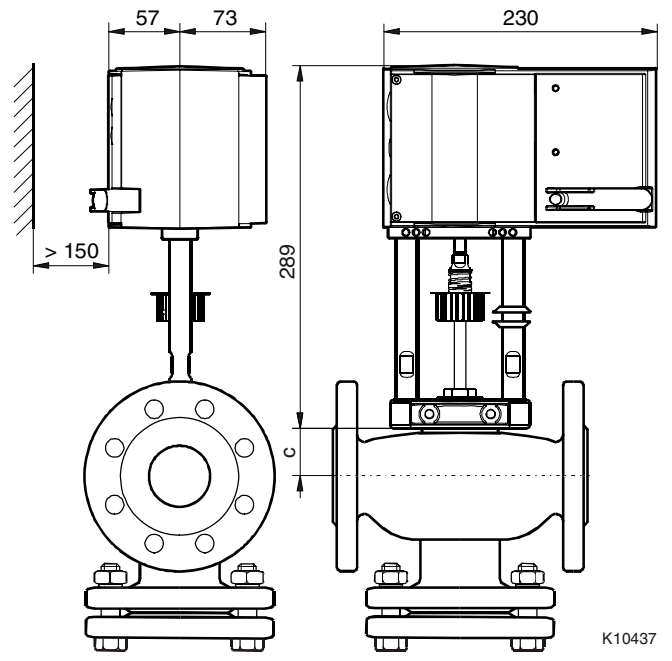

Accessories

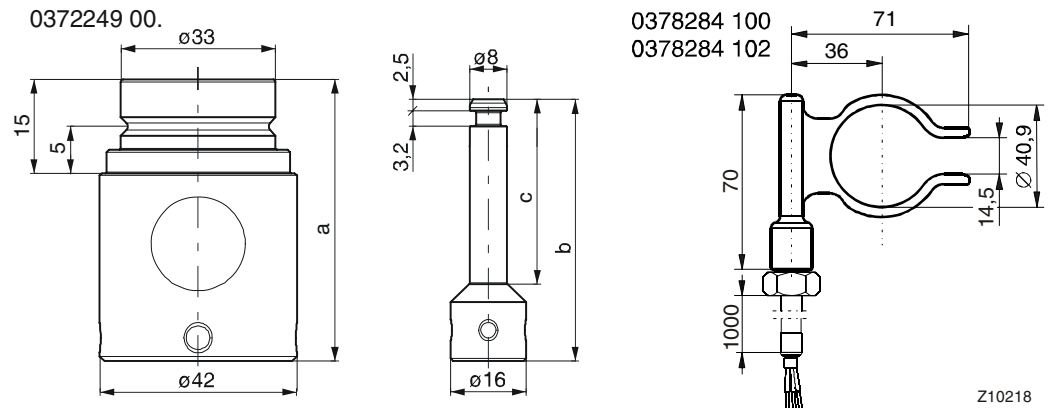
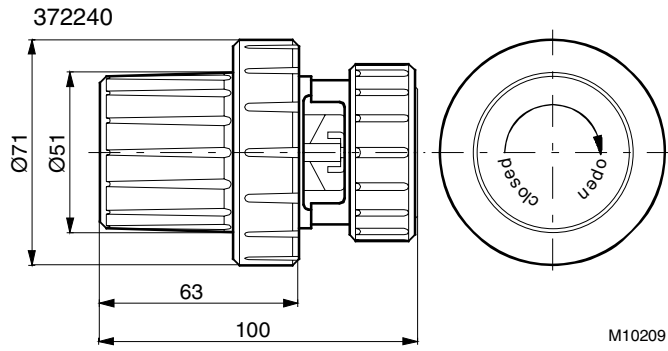

	a [mm]	b [mm]	c [mm]
0372249 001	60	55,8	40
0372249 002	80	75,8	60

Z10220