

VUG: Flanged through valve, PN 25/16

Control valve, free of silicone grease regulating valve for continuous control of cold water, warm water, hot water, steam or air in HVAC installations. Condition of the water in accordance with VDI 2035. Used together with the AVM 234S, AVF 234S and AVN 224S actuators as a regulating unit. Valve tested to DIN 32730 ^{1) 2) 3)}.

Valve body of ductile cast iron (EN-GJS-400-18-LT), painted black. Spindle, valve seat and plug of stainless steel. Plug from DN 15 to DN 50 with glass-fibre-reinforced Teflon sealing ring. Packing box of brass with spring-load Teflon disc. Valve characteristic is equal-percentage, linear or quadratic (can be changed) with SUT actuators. Closes either with or against the pressure. For use with a PN 16 or PN 25 counter flange. When the spindle is extended, the valve is closed.



T10430



Y07544

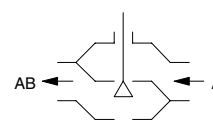

B01133a

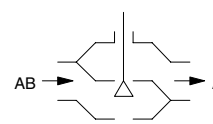

B01138a

Type	Nominal diameter	Connection	k _{VS} value	Weight
	DN		m ³ /h	kg
VUG 015 F374	15	PN 25/16	0,16	4,0
VUG 015 F364	15	PN 25/16	0,25	4,0
VUG 015 F354	15	PN 25/16	0,40	4,0
VUG 015 F344	15	PN 25/16	0,63	4,0
VUG 015 F334	15	PN 25/16	1	4,0
VUG 015 F324	15	PN 25/16	1,6	4,0
VUG 015 F314	15	PN 25/16	2,5	4,0
VUG 015 F304	15	PN 25/16	4	4,0
VUG 020 F304	20	PN 25/16	6,3	5,0
VUG 025 F304	25	PN 25/16	10	5,6
VUG 032 F304	32	PN 25/16	16	9,1
VUG 040 F304	40	PN 25/16	25	11,2
VUG 050 F304	50	PN 25/16	40	13,8
VUG 065 F316	65	PN 16	63	25
VUG 065 F304	65	PN 25	63	25
VUG 080 F304	80	PN 25/16	100	37
VUG 100 F304	100	PN 25	160	50
VUG 125 F304	125	PN 25	250	75
VUG 150 F304	150	PN 25	340	100

Operating temperature ¹⁾	-20...240 °C	Dimension drawing	
Operating pressure	up to 120 °C 25 bar	DN 15...50 (65)	M10427
	up to 240 °C 20 bar	DN 65...150	M10447
	-20...-10 °C 18 bar	Fitting instructions	
Valve characteristic	equal-percentage	DN 15...50	MV 505947
Valve's control ratio	> 50:1	DN 65...150	MV 505973
Packing box	Brass/Teflon	AVM 234/assembly	MV 505919
Leakage rate at max. Δps:	≤ 0,05% of k _{VS} value	AVF 234/assembly	MV 505920
Valve stroke		AVN 224/assembly	MV 505927
DN 15...50	20 mm	Declaration on materials	MD 56.120
DN 65...150	40 mm		

Accessories

- [0372336 180*](#) Adaptor (required for media > 130 °C / < 180 °C; MV 505902)
- [0372336 240*](#) Adaptor (required for media > 180 °C / < 240 °C; MV 505902)
- [0378283 001](#) Replacement packing for packing box of diameter DN 15-150; MV 505950
- [0378284 100*](#) Heater for packing box 230 V~, 15 W for media below 0 °C; MV 505978
- [0378284 102*](#) Heater for packing box 24 V~, 15 W for media below 0 °C; MV 505978
- [0378285 001](#) Packing box, stainless steel/Teflon DN 15...150
- [0378384 001](#) Anti-torsion device DN 65...150

^{*)} Dimension drawing or wiring diagram are available under the same number

- 1) At temperatures below 0 °C, use packing-box heater (accessory). At temperatures above 130 °C or 180 °C, use the appropriate adaptor (accessory).
Up to -10 °C as per AD notice W 10, water with de-icing agent and brine.
For use in accordance with DIN 32730, the permissible temperature of the medium is > 0 °C.
- 2) The VUG 065 F316 valves do not have TÜV approval. They do not bear the test institute's code and are classified under Category I of the Directive on Pressure Equipment. These valves can be employed with the AVN 224S F... actuator, but not as a safety unit
- 3) DIN 32730 has been substituted by DIN EN 14597.

Warranty The technical data and pressure differences stated above apply only when used in combination with Sauter actuators. If used together with actuators of a different manufacturer, the warranty becomes invalid.

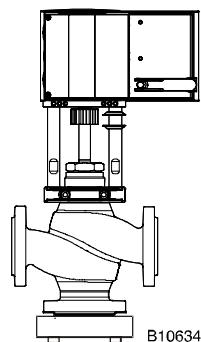
VUG combined with electric actuator (combination without 230 V module or accessory).

Actuator	without spring return 2500 N pushing force:					
Type:	AVM 234 S F132 (24 V)					
Running time:	2 / 4 / 6 s/mm					
Input:	2pt / 3pt / 0...10 V / 4...20 mA					
Valve	Against the pressure			With the pressure		
	Δp_{max}	Δp_s	close/off pressure	Δp_{max}	Δp_s	close/off pressure
VUG 015	16	–	25	6	–	25
VUG 020	16	–	25	6	–	25
VUG 025	16	–	25	6	–	25
VUG 032	16	–	25	6	–	24
VUG 040	16	–	17	6	–	15,5
VUG 050	11	–	11	6	–	10
VUG 065	7,1	–	7,1	4,5	–	6,5
VUG 080	4,7	–	4,7	3,5	–	4,4
VUG 100	3,0	–	3,0	3,0	–	2,8
VUG 125	2,0	–	2,0	2,0	–	2,0
VUG 150	1,5	–	1,5	1,0	–	1,5

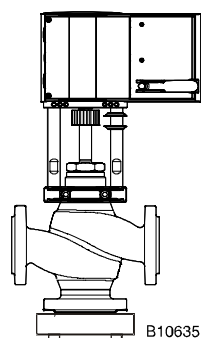

Actuator	with spring return 2000 N pushing force					
Type:	AVF 234 S F132 (24 V)					
Running time:	2 / 4 / 6 s/mm					
Input:	2pt / 3pt / 0...10 V / 4...20 mA					
Spring return:	15 ... 30 s					
Valve	Against the pressure			With the pressure		
	Δp_{max}	Δp_s	close/off pressure	Δp_{max}	Δp_s	close/off pressure
VUG 015	16	25	25	6	25	25
VUG 020	16	25	25	6	25	25
VUG 025	16	25	25	6	25	25
VUG 032	16	21	21	6	25	18
VUG 040	13,5	13,5	13,5	6	25	12
VUG 050	8,5	8,5	8,5	6	25	7,5
VUG 065	5,6	5,6	5,6	4,5	25	5,1
VUG 080	3,4	3,4	3,4	3,4	25	3,4
VUG 100	2,2	2,2	2,2	2,2	25	2,2
VUG 125	1,6	1,6	1,6	1,6	25	1,6
VUG 150	1,2	1,2	1,2	1,0	25	1,2

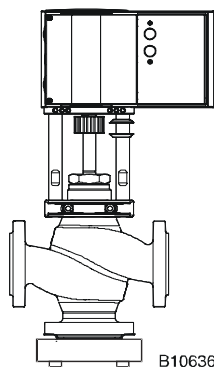

Actuator	with emergency function as per DIN 32730 1100 N pushing force (look ² page 1)					
Type:	AVN 224 S F132 (24 V)					
Running time:	2 / 4 / 6 s/mm					
Input:	2pt / 3pt / 0...10 V / 4...20 mA					
Spring return:	15 ... 30 s					
Valve	Against the pressure			With the pressure		
	Δp_{max}	Δp_s	close/off pressure	Δp_{max}	Δp_s	close/off pressure
VUG 015	16	25	25	6	25	25
VUG 020	16	25	25	6	25	22
VUG 025	16	17	17	6	25	14,5
VUG 032	10,5	10,5	10,5	6	25	9,4
VUG 040	6,5	6,5	6,5	6	25	6,5
VUG 050	4	4,0	4,0	4	25	4,0
VUG 065	3,0	3,0	3,0	2,6	25	2,6
VUG 080	2,0	2,0	2,0	1,7	25	1,7
VUG 100	1,1	1,1	1,1	1,1	25	1,1
VUG 125	0,8	0,8	0,8	0,8	25	0,8
VUG 150	0,6	0,6	0,6	0,6	25	0,6

Valve: For F-variant, technical data and accessories, see table of valve types.

Actuator: For F-variant, technical data, accessories and fitting position, see table of valve types.

Example: VUG 040 F304 / AVM 234 S F132

Δp_{max} [bar]= Max. permissible pressure difference across the valve at which the drive can still firmly open and close the valve while taking Δp_v into account.

Δp_s [bar]= Max. permissible pressure difference across the valve at which, in the event of a malfunction (pipe break after the valve), the drive can close the valve firmly and quickly.

close/off pressure [bar]= Max. possible pressure difference across the valve (in control mode) at which the drive can still firmly open and close the valve. In this mode, the serviceable life may be reduced. Cavitation, erosion and surges may damage the valve. The values apply only when the valve is fitted to the drive as a unit.

Operation

Using an electric drive, the valve can be moved to any position. The valve's control passage closes when the valve spindle is extended. These valves can be used to close either with or against the operating pressure. Please observe the direction of flow marked on the valve; if used 'with the pressure', the arrow should be covered with a label (which can be found on the Fitting Instructions). Fluidic variables in accordance with EN 60534.

Closes against the pressure

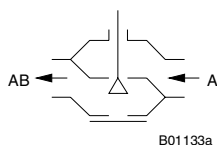

Closes with the pressure

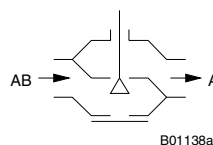

Description

These control valves are distinguished by their great reliability and accuracy and make an important contribution towards efficient control. They run very quietly and meet sophisticated requirements, e.g. provide safety functions, overcome differential pressures, control the temperature of the medium and provide a cut-off function.

The valve spindle is fixed to the drive spindle automatically. Sauter's shaped stainless-steel plug regulates an equal-percentage throughflow in the control passage. The valve's high level of seal is guaranteed by a stainless-steel ring pressed into the valve seat.

The packing box requires no maintenance. It comprises six conically formed Teflon ring plus a spring. The spring ensures a permanent tension on the seals, which guarantees their tightness with regard to the valve spindle. In addition, a supply of grease ensures that the valve spindle is always lubricated. Furthermore, the grease prevents particles from entering the medium and reaching the Teflon seal.

Engineering and fitting notes

The valves are combined with the AVM 234 S actuators without spring return or the AVF 234 S, AVN 224 S actuators with spring return. The drive is slotted onto the valve and fixed with screws. The drive locks onto the valve spindle automatically. When the installation is put into service, the AVM 234 S and the AVF 234 S actuators extend and the coupling automatically makes the connection to the valve as soon as it reaches the lower valve seat. The valve stroke is also detected by the actuator; no further settings are necessary. The force acting on the seat is therefore always constant and the leakage is guaranteed. These actuators allow the characteristic to be changed from linear to quadratic or vice versa.

If AVN 224 S damper drives are employed, the drive must be manually initialised. For a full description of this, see PDS 51.379: 'Initialisation and feedback signal'.

Fitting position

The control unit can be fitted in any position except facing downwards. The ingress of condensate, drops of water etc. into the drive should be prevented. If fitted horizontally, and with regard to the valve spindle, the maximum permissible weight on the valve is 25 kg unless the actuator is supported (to be carried out by the client) or is subject to forces acting otherwise.

up to 130 °C In any position except facing downwards.

above 130 °C At temperatures above 130 °C or 180 °C, the valve should be fitted in the horizontal position and the correct adaptor for the relevant temperature should be employed. The adaptor can also serve as an extension, allowing the actuator to protrude from the piping insulation. To protect the actuator against heat, the pipes should be insulated.

When fitting the drive to the valve, care must be taken not to turn the valve plug on the stainless-steel seat, otherwise the seal may be damaged. When insulating the valve, the insulation should not extend beyond the connecting clamp on the drive.

Using with steam

The valves can be used for steam applications up to 200 °C with the same Δp_{\max} values. We recommend, however, that the valves be used only for open/close operations. When used as a control valve, care should be taken to ensure that valve does not function largely in the bottom third of its stroke range. This results in an extremely high flow speed, which greatly reduces the valve's serviceable life.

Using with water

In order to restrain contaminants in the water (e.g. welding beads, rust particles etc.) and prevent the spindle seal from being damaged, we recommend the employment of collective filters, e.g. for each floor or feed pipe. The composition of the water should be in accordance with VDI 2035. If an auxiliary medium is used, please contact the supplier of the medium in order to clarify whether the valve materials are compatible. Please refer to the materials table below. If glycol is used, we recommend a concentration of between 20% and 55%. The valves are not suitable for use with drinking water or in zones where there is a risk of explosion.

Approval for DIN 32730

With exception of the VUG 065 F316 the valves can be employed together with the AVN 224 S actuator with emergency function in accordance with DIN 32730.

Other notes concerning hydraulics and noise in installations

The valves can be employed in quiet surroundings. To prevent noise, the Δp_{\max} pressure differences listed below should not be exceeded. These values are listed as recommended values in the table of pressure losses.

The pressure difference Δp_v is the highest pressure permitted to act on the valve, regardless of the stroke position, so that the risk of cavitation and erosion is limited. The force of the actuator has no influence on these values. Cavitation accelerates wear and causes noise. In order to prevent cavitation, particularly in applications with steam, the pressure difference Δp_{\max} should not exceed the value $\Delta p_{\text{krit}} = (p_1 - p_v) \times 0,5$

p_1 = Upstream pressure before the valve (bar) p_v = Steam pressure

Absolute pressure was used in these calculations.

The close/off pressure values are the maximal pressures at which the actuator can still move the valve with its own force. Please note that the valve may be damaged by cavitation and erosion if these pressures are used and the pressure difference Δp_{\max} is exceeded. As far as the spring-return function is concerned, the stated Δp_s values also represent the permissible differential pressure, up to which the actuator can still close the valve in the event of an emergency. Since this is a safety function with fast stroke (by means of a spring), this value may exceed Δp_{\max} .

Flow-rate chart VUG

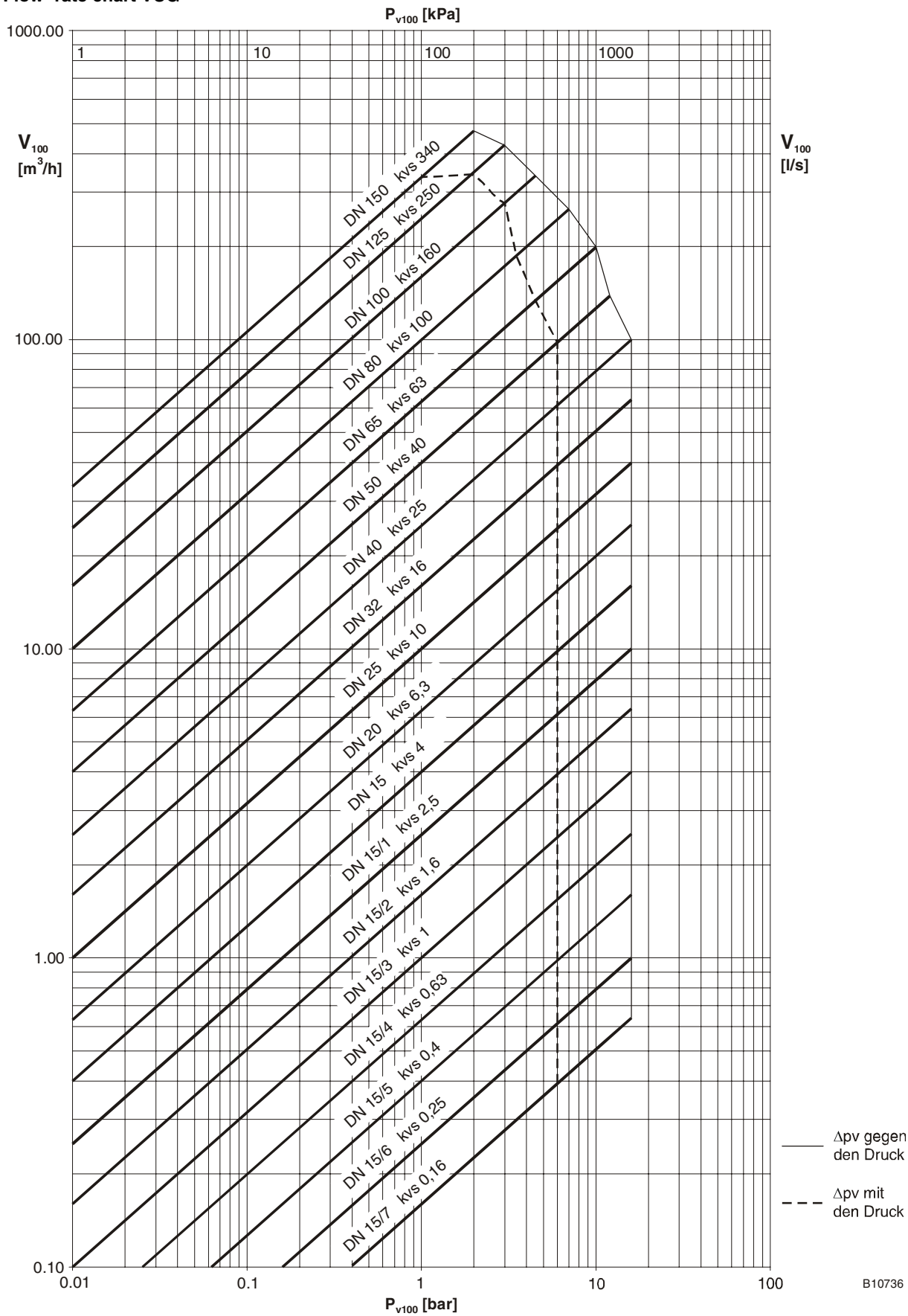

B10736

Additional technical data

Type	Δp_v	
	Against the pressure	With the pressure
VUG 015 F374	16 bar	6 bar
VUG 015 F364	16 bar	6 bar
VUG 015 F354	16 bar	6 bar
VUG 015 F344	16 bar	6 bar
VUG 015 F334	16 bar	6 bar
VUG 015 F324	16 bar	6 bar
VUG 015 F314	16 bar	6 bar
VUG 015 F304	16 bar	6 bar
VUG 020 F304	16 bar	6 bar
VUG 025 F304	16 bar	6 bar
VUG 032 F304	16 bar	6 bar
VUG 040 F304	16 bar	6 bar
VUG 050 F304	12 bar	6 bar
VUG 065 F304	10 bar	4,5 bar
VUF 065 F316	10 bar	4,5 bar
VUG 080 F304	7 bar	3,5 bar
VUG 100 F304	4,5 bar	3 bar
VUG 125 F304	3 bar	2 bar
VUG 150 F304	2 bar	1 bar

Pressure and temperature specifications

Flow parameters

Sauter slide rule for valve sizing

Slide rule manual

Technical manual: 'Valves and drives'

Parameters, Installation Notes, Control, General Information

CE conformity, Directive of Pressure Equipment (Fluid Group II)

VUG 065 F316 CE mark

VUG ... with AVN 224S F132: CE-0035 mark

(look ²) page 1)

VUG ... without AVN 224S F132: CE-0035 mark

EN 764, EN 1333

EN 60534 (Page 2)

7 090011 003

7 000129 003

7 000477 003

Valid EN, DIN,

AD, TRD and UVV

regulations

97/23/EG

Category I

Category IV

DIN 32730

Category II

Additional details on model types

Valve body of ductile cast iron as per EN 1563, code EN-GJS-400-18-LT, material number EN-JS1025, with smooth-drilled flanges as per EN 1092-2, Form B sealing strip. Valve body protected by a matt coating, black as per RAL 9005. Recommendations for the welding flange as per EN 1092-1. Valve fitting width as per EN 558-1, Series 1. Flat seal on the body of the valve of asbestos-free material.

Material numbers as per DIN

	DIN material no.	DIN code
Valve body	EN-JS1025	EN-GJS-400-18-LT (GGG40.3)
Valve seat	1.4021	X 20 Cr 13
Spindle	1.4305	X 8 Cr Ni S 18-9
Plug	1.4305	X 8 Cr Ni S 18-9
Plug seal	PTFE	reinforced with fibre glass
Packing box	CW 617 N	Cu Zn 40 Pb 2
Seal underneath packing box	CW024A	Cu-DHP

Explanation of terms used

Δp_v :

Maximum permissible pressure difference across the valve in any stroke position, limited by the noise level and erosion.

The valve as a traversed element is defined by this parameter specifically in its hydraulic behaviour. By monitoring cavitation, erosion and the noise thus produced, improvements can be achieved in both life expectancy and durability.

Δp_{max} :

Maximum permissible pressure difference across the valve at which the drive can firmly open and close the valve.

Static pressure and fluidic influences are taken into account. This value helps to maintain a smooth stroke action and the high level of sealing. In doing so, the valve's Δp_v value is never exceeded.

Δp_s :

Maximum permissible pressure difference across the valve in the event of a malfunction (e.g. power failure, excess temperature or pressure, burst pipe) at which the drive can firmly close the valve and, if necessary, hold the full operating pressure against atmospheric pressure. Since this is a safety function with 'fast' stroke, Δp_s can be larger than Δp_{max} or, respectively, Δp_v . The resultant fluidic disturbances are soon overcome and play a minor role here.

On the three-way valves, the values apply only for the control passage.

Δp_{stat} :

Line pressure behind the valve. This corresponds largely to the dead pressure when the pump is switched off, e.g. due to the level of liquid in the installation, an increase in pressure via the pressure store, steam pressure etc.

For valves that close with the pressure, the static pressure plus the pump pressure should be used.

Characteristic for actuators with positioner (24 V only)

On the AVM 234 S, AVF 234 S or AVN 224 S actuator

Equal-percentage/linear/quadratic
settable using the coding switch

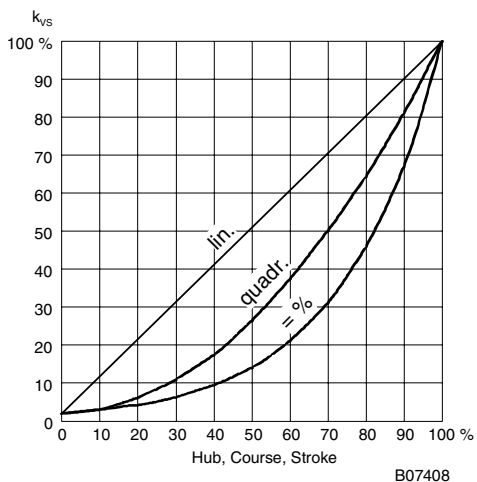

Dimension drawings

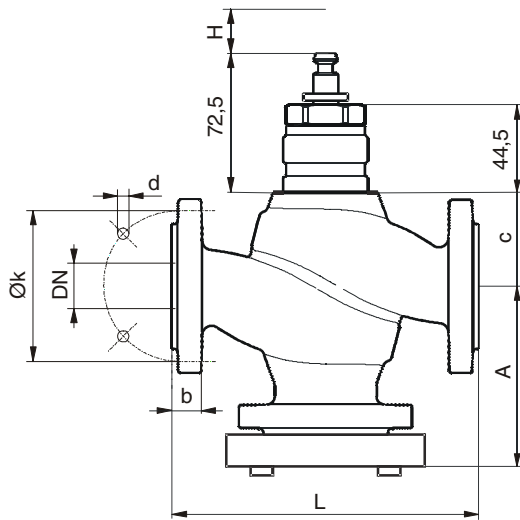

VUG	DN	A	c	L	H	k	d	b
015	15	84	54	130	20	65	14 x 4	14
020	20	94	48	150	20	75	14 x 4	16
025	25	97	50	160	20	85	14 x 4	16
032	32	110	59	180	20	100	19 x 4	18
040	40	116	63	200	20	110	19 x 4	19
050	50	126	67	230	20	125	19 x 4	19
065	65/ PN16	144	163	290	40	145	19 x 4	19

M10427d

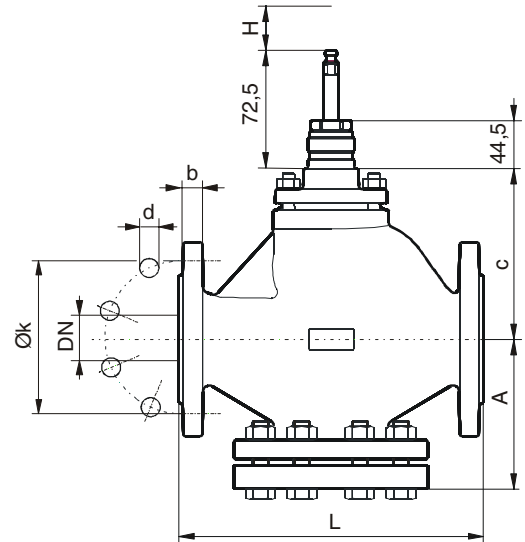

VUG	DN	A	c	L	H	k	d	b
065	65/PN25	144	163	290	40	145	19 x 8	19
080	80	156	182	310	40	160	19 x 8	19
100	100	176	183	350	40	190	23 x 8	19
125	125	228	223	400	40	220	28 x 8	19
150	150	242	257	480	40	250	28 x 8	20

M10447b

AVM

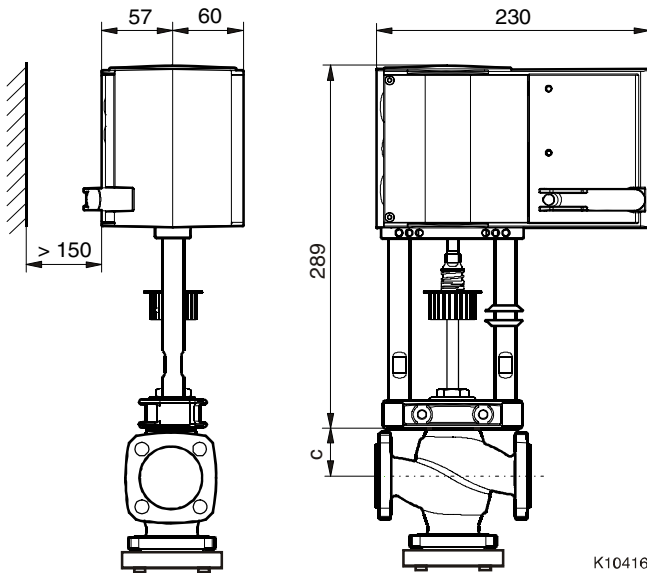

K10416

AVF

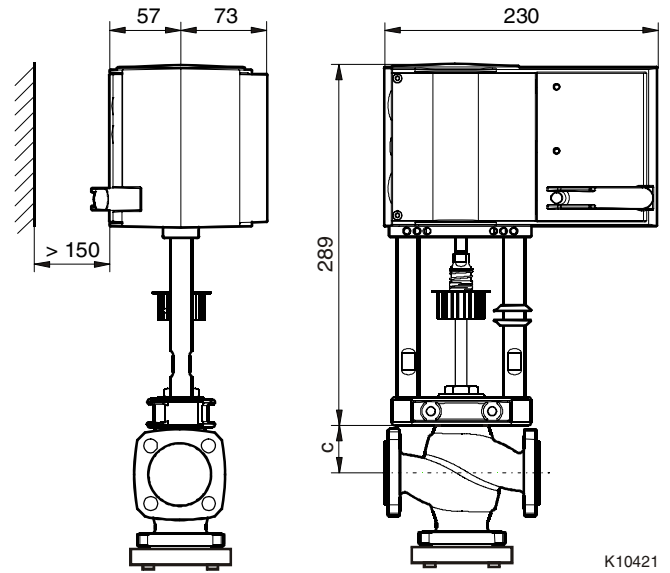

K10421

AVN

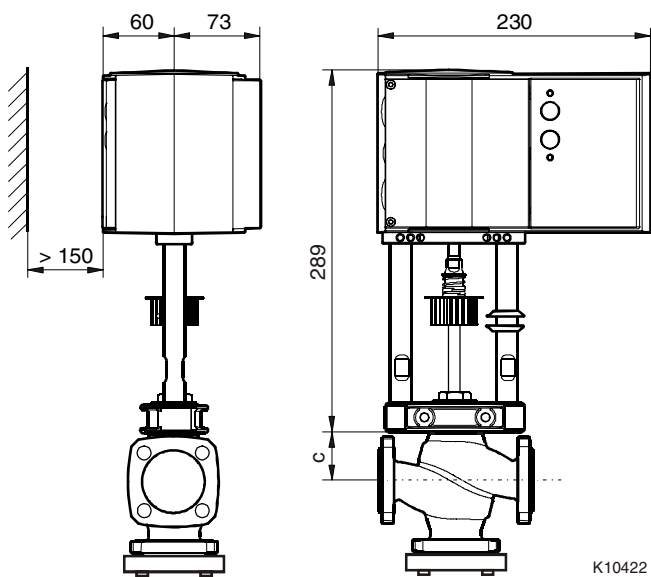

K10422

Accessories

0372336 180
0372336 240

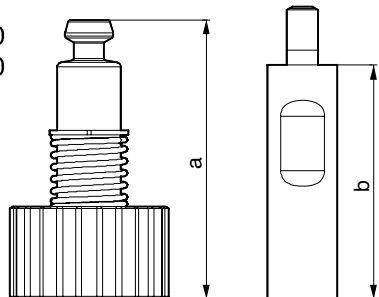

0372336	T (°C)	a (mm)	b (mm)
180	180	69,4	60
240	240	109,4	100

Z10217

0378284 100
0378284 102

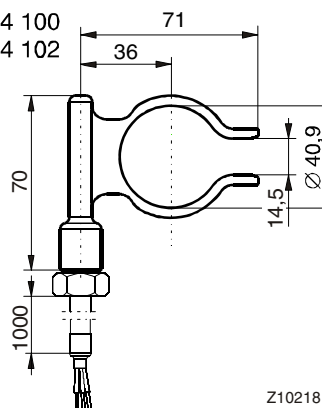

Z10218