

VUL: Unit through valve (regulating), PN 16

Used in conjunction with either the AXT 111 thermal drive for unit valves, the continuous AXS 111S drive or the AXM 117(S) motorised drive for unit valves for the control of heating zones, air secondary-treatment appliances and fan convectors.

Valve and drive are assembled either by simply screwing together or by using the bayonet fitting. Nickel-plated (DN 10) valve body of cast brass, DN 15 and DN 20 of gunmetal with male thread, without cap nut. Spindle of stainless steel with soft-sealing valve cone. Characteristic practically equal-percentage. Stuffing box with double O-ring seal. The through valve is closed when the spindle is pressed in.



T10189



Y07544

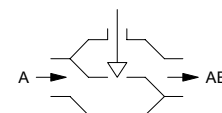

B01591

Type	Nominal dia. DN	k _{vs} value m ³ /h	Connection	Weight kg
VUL 010 F340	10	0,16	G½B	0,19
VUL 010 F330	10	0,40	G½B	0,18
VUL 010 F320	10	0,63	G½B	0,18
VUL 010 F310	10	1,0	G½B	0,18
VUL 010 F300	10	1,6	G½B	0,18
VUL 015 F310	15	2,5	G¾B	0,28
VUL 015 F300	15	3,5	G¾B	0,28
VUL 020 F300	20	4,5	G1B	0,33

Version for compression fitting for pipe Ø 15 mm

VUL 010 F630	10	0,40	–	0,18
VUL 010 F620	10	0,63	–	0,18
VUL 010 F610	10	1,0	–	0,18
VUL 010 F600	10	1,6	–	0,18

Nominal pressure	PN 16	Leakage rate	0,0001% of k _{vs}
Max. operating pressure	up to 120 °C, 16 bar	Dimension drawing	M10121
Operating temperature	2...120 °C	Fitting instructions	MV 505864
Characteristic	equal-percentage	fitted onto AXT 111	MV 505511
Valve stroke	4 mm ¹⁾	with auxiliary contacts	MV 505822
		fitted onto AXS 111S	MV 505821
		fitted onto AXM 117/117S	MV 505456
		fitted onto AXM 117 F200	MV 505816
		Declaration of materials	MD 55.008

Accessories

- 0378133 010*** 1 threaded sleeve, R ¾ flat seal DN 10 with cap nut and flat seal
- 0378133 015*** 1 threaded sleeve, R ½ flat seal DN 15 with cap nut and flat seal
- 0378133 020*** 1 threaded sleeve, R ¼ flat seal DN 20 with cap nut and flat seal
- 0378134 010*** 1 solder nipple, Ø 12; flat seal DN 10, with cap nut and flat seal
- 0378134 015*** 1 solder nipple, Ø 15; flat seal DN 15, with cap nut and flat seal
- 0378134 020*** 1 solder nipple, Ø 22; flat seal DN 20, with cap nut and flat seal
- 0378135 010** 1 compression fitting for pipe Ø 15 mm, DN 10
- 0378145 015*** 1 compression fitting for pipes of Ø 15 mm, DN 15, flat seal ¾ B
- 0378145 020*** 1 compression fitting for pipes of Ø 22 mm, DN 20, flat seal 1 B
- 0378128 001** Stuffing box for VUL valves, can be replaced under pressure

*) Dimension drawing or wiring diagram are available under the same number

1) The stroke of the valve is limited by the valve drive

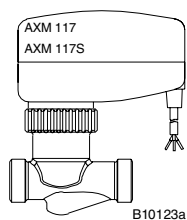
Combined with a 24 V electric drive, AXM 117 F202 AXM 117S F . . .

Actuator	Closes against the pressure			AXM 117 F202	AXM 117S F . 0 .
	Δp_{\max}	Δp_s	close/off pressure		
VUL 010 F340	4,0	–	6,0		
VUL 010 F330	4,0	–	6,0		
VUL 010 F630	4,0	–	6,0		
VUL 010 F320	4,0	–	6,0		
VUL 010 F620	4,0	–	6,0		
VUL 010 F310	3,8	–	4,0		
VUL 010 F610	3,8	–	4,0		
VUL 010 F300	3,8	–	4,0		
VUL 010 F600	3,8	–	4,0		
VUL 015 F310	1,1	–	1,1		
VUL 015 F300	1,1	–	1,1		
VUL 020 F300	1,1	–	1,1		

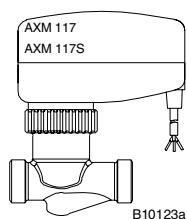
Combined with a 230 V electric drive, AXM 117 F200

Actuator	Closes against the pressure			AXM 117 F200
	Δp_{\max}	Δp_s	close/off pressure	
VUL 010 F340	4,0	–	6,0	
VUL 010 F330	4,0	–	6,0	
VUL 010 F630	4,0	–	6,0	
VUL 010 F320	4,0	–	6,0	
VUL 010 F620	4,0	–	6,0	
VUL 010 F310	4,0	–	5,0	
VUL 010 F610	4,0	–	5,0	
VUL 010 F300	4,0	–	5,0	
VUL 010 F600	4,0	–	5,0	
VUL 015 F310	1,7	–	1,7	
VUL 015 F300	1,7	–	1,7	
VUL 020 F300	1,5	–	1,7	

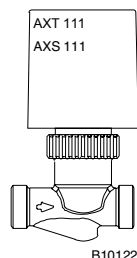
Combined with a thermal and continuous drive, AXT 111 F . . . AXS 111S F . . .

Actuator	Closes against the pressure			AXT 111 F200, F202	AXS 111S F . 0 .
	Δp_{\max}	Δp_s	close/off pressure		
VUL 010 F340	4,0	6,0	6,0		
VUL 010 F330	4,0	6,0	6,0		
VUL 010 F630	4,0	6,0	6,0		
VUL 010 F320	4,0	6,0	6,0		
VUL 010 F620	4,0	6,0	6,0		
VUL 010 F310	4,0	4,0	4,0		
VUL 010 F610	4,0	4,0	4,0		
VUL 010 F300	4,0	4,0	4,0		
VUL 010 F600	4,0	4,0	4,0		
VUL 015 F310	1,6	1,6	1,6		
VUL 015 F300	1,6	1,6	1,6		
VUL 020 F300	1,6	1,6	1,6		

Complete type code for valve and actuator with F variant

Valve: For F variant, technical data and accessories, see table of valve types

Actuator: For F variant, technical data, accessories and fitting position, see Section 55

Example: VUL 015 F310/AXM 117S F202

Δp_{\max} [bar]= Max. permissible pressure difference across the valve at which the actuator can still firmly open and close the valve. Figures stated are for a static pressure of 6 bar; at a static pressure of 16 bar, the values are reduced by 15%.

Δp_s [bar]= Max. permissible pressure difference across the valve at which, in the event of a malfunction, the actuator can close the valve.

Close/off pressure The pressure difference across the valve in control mode that the force of the drive can overcome. In this mode, a reduced serviceable life can be expected. Cavitation, erosion and pressure surges may damage the valve. The values stated apply only when the valve is fitted to the actuator.

Operation

The through valve (passage A-AB) is closed by pressing the spindle in; it is returned by spring pressure (the spring is in the valve). The AXT 111 thermal drive can be used to move the valve to the OPEN or CLOSED position. Used in combination with the 'normally closed' drive version, the control passage closes in the event of power failure.

Used with the AXM 111S drive, the valve can be moved to any position. Depending on the way the control voltage is connected, the valve is moved continuously with a control voltage of 0...10 V. Connected to red cable: passage A-AB opens as the control voltage rises. Connected to white cable: the passage closes as the control voltage rises.

Used with the AXM 117 motorised drive, the valve can be moved to any position. On the AXM 117S (with positioner), the valve is moved continuously by a control voltage of 0...10 V-. Variants: F202 opens (and F302 closes) the control passage as the control voltage rises.

Used with a continuous drive (0...10 V), the practically equal-percentage characteristic provides optimum control.

Engineering and fitting notes

The final control element can be fitted in any position except facing downwards. The ingress of condensate, dripping water etc. into the drive should be prevented.

In order to prevent cavitation noise from affecting rooms where quietness is essential, the pressure difference across the valve should not exceed 0,8 bar.

In order to restrain contaminants in the water (e.g. welding beads, rust particles etc.) and prevent the spindle seal from being damaged, we recommend the employment of collective filters, e.g. for each floor or feed pipe. The composition of the water should be in accordance with VDI 2035.

The stuffing box can be replaced even when the valve is under pressure; no additional tools are required to do so. The stuffing box is sealed with regard to the medium. Medium with coolant such as glycol, min. 16% max. 40%.

When insulating the unit valve, the insulation should not extend beyond the cap nut or the bayonet ring on the drive.

Additional technical data

Nickel-plated (DN10) valve body of cast brass, DN15 and DN20 of gunmetal with male thread, as per ISO 228/1, Class B, flat seal on body. Stuffing box with O ring of ethylene-propylene; protective cap (or manual-adjustment knob) of plastic.

Material numbers as per DIN

	DIN material no.	EN-DIN code
Valve body DN10	CW617N	Cu Zn 40 Pb2 as per EN12164
Valve body DN15 and DN20	CC490K	Cu Sn 3 Zn 8 Pb5-C as per EN1982
Valve seat DN10	CW617N	Cu Zn 40 Pb2 as per EN12164
Valve seat DN15 and DN20	CC490K	Cu Sn 3 Zn 8 Pb5-C as per EN1982
Spindle	1.4310	X10 Cr Ni18-8 as per EN188-1
Plug	CW617N	Cu Zn 40 Pb2 as per EN12164
Stuffing box	CW617N	Cu Zn 40 Pb2 as per EN12164

Technical information

- Pressure and temperature specifications EN764, EN1333
- Flow parameters VDI/VDE 2173
- Sauter slide rule for valve sizing 7 090011 003
- Slide rule manual 7 000129 003
- PC program: Valve and drive sizing 7 000675 003
- Valvedim.exe
- Technical manual: 'Regulating units' 7 000477 003
- CE conformity: Directive on Pressure Equipment 97/23/EG Article 3.3 (Fluid group II)

Dimension drawing

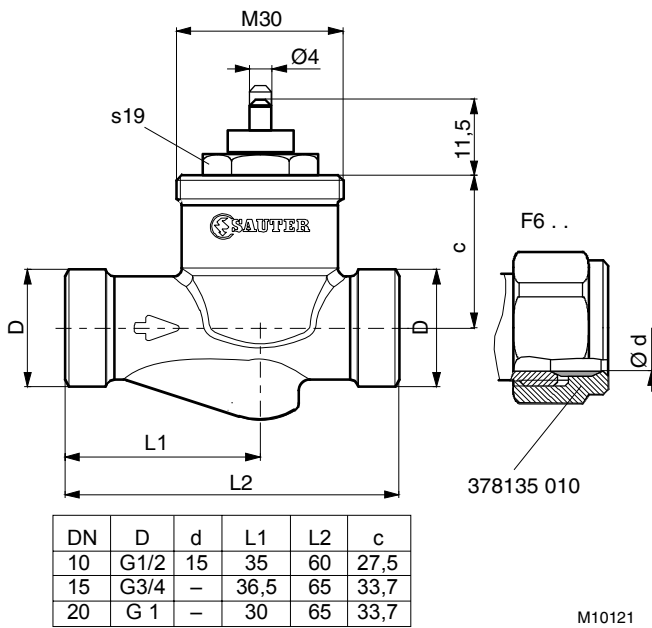

M10121

Accessories

Screw-type fitting

378133

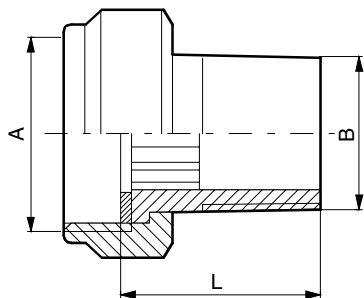

DN	A	B	L
10	G1/2	R3/8	24
15	G3/4	R1/2	27,5
20	G1	R3/4	32,5

M10143

Soldered fitting

378134

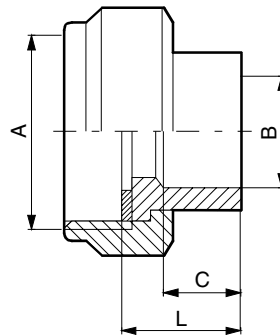

DN	A	B	C	L
10	G1/2	12	8,6	14
15	G3/4	15	10,6	15,5
20	G1	22	15,4	20

M10144

Compression fitting

0378145

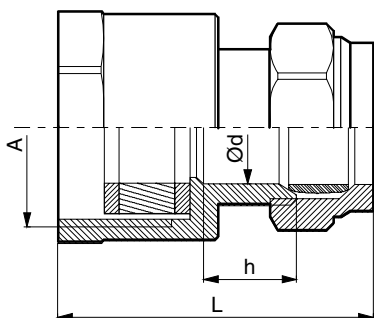

DN	A	L	Ød	h
15	G3/4	39	15,2	12,5
20	G1	41,5	22,2	16

Z10211

Assembly

Combinations with AXT thermal drive and AXM motorised drive

AXT 111

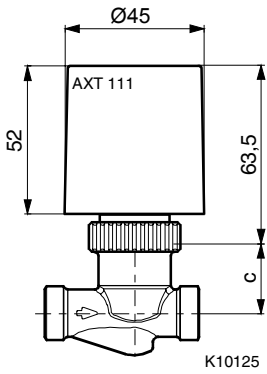

AXS 111S

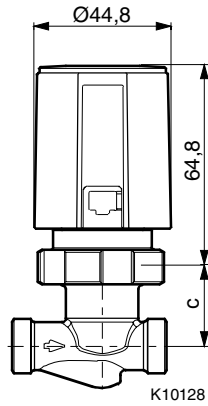

AXM 117/117S

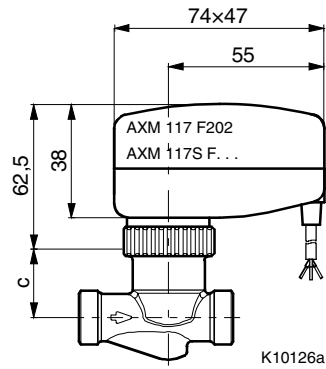

AXM 117 F200

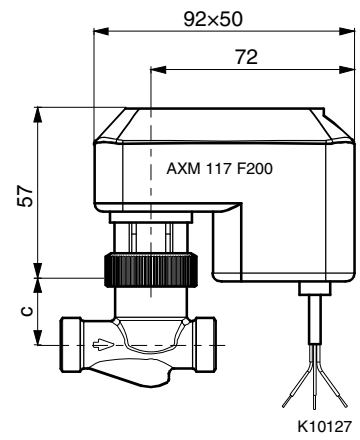

Table of pressure losses for VUL and BUL valves

