

VUN: Through valve with male thread, PN 16

Usage areas

Control valve for continuous regulation of cold water, hot water or air in closed circuits¹⁾. Water characteristics in accordance with VDI 2035. In conjunction with valve drives AVM 105(S), 115(S), 124, 125S and AVF 124, 125S as an actuator.

Characteristics

- Free of silicon grease
- Valve unit and valve seat made from dezincification-free cast brass
- Spindle made from stainless steel
- Plug made from zinc-free brass with glass fibre-reinforced Teflon sealing ring
- Equal percentage characteristic curve, adjustable with SUT valve drives on linear or quadratic
- The valve is closed when the stem is extended

Technical description

- Valve with male thread in accordance with DIN EN ISO 228-1
- Stuffing box made from dezincification-free brass with scraper ring and double O-ring seal made from EPDM

Type	Nominal Diameter DN	Connection	k _{VS} -Value m ³ /h	Weight kg
VUN 015 F350	15	G 1B	0,4	0,82
VUN 015 F340	15	G 1B	0,63	0,82
VUN 015 F330	15	G 1B	1	0,82
VUN 015 F320	15	G 1B	1,6	0,82
VUN 015 F310	15	G 1B	2,5	0,82
VUN 015 F300	15	G 1B	4	0,82
VUN 020 F300	20	G 1¼B	6,3	1,00
VUN 025 F300	25	G 1½B	10	1,30
VUN 032 F300	32	G 2B	16	1,74
VUN 040 F300	40	G 2¼B	22	2,52
VUN 050 F300	50	G 2¾B	28	3,44
VUN 050 F200	50	G 2¾B	40	3,44

Operating temperature ²⁾	-15...150 °C	Dimension drawing	M10491
Operating pressure	up to 120 °C 16 bar up to 130 °C 13 bar up to 150 °C 10 bar	Fitting instructions	P100001118
Valve characteristic	F200 linear F3.0 Equal-percentage	AVM 105(S), 115(S)	MV506065
Control ratio	> 50:1 (typical)	AVM 124	MV505809
Leakage rate	≤ 0,02% of k _{VS} -Value	AVM 125S	MV506066
Nominal stroke	8 mm	AVF 124	MV505851
		AVF 125S	MV506067
		Declaration on materials and the environment	MD 56.100

Accessories

0361951 015*	1 screw fitting for male thread with flat seal DN 15
0361951 020*	1 screw fitting for male thread with flat seal DN 20
0361951 025*	1 screw fitting for male thread with flat seal DN 25
0361951 032*	1 screw fitting for male thread with flat seal DN 32
0361951 040*	1 screw fitting for male thread with flat seal DN 40
0361951 050*	1 screw fitting for male thread with flat seal DN 50
0372240 001*	Manual adjustment for valves with 8 mm stroke; MV 505813
0372249 001*	Temperature adapter (>100 °C up to max. 130 °C) for AVM, DN 15...50, MV 505932
0372249 002*	Temperature adapter (>130 °C up to max. 150 °C) for AVM, DN 15...50, MV 505932
0378284 100*	Stuffing box heater 230 V~; 15W, for Media below 0 °C, DN 15...50, MV 505978
0378284 102*	Stuffing box heater 24 V~; 15W, for Media below 0 °C, DN 15...50, MV 505978
0378368 001	Complete spare stuffing box for DN 15 to DN 50

*) Dimension drawing or wiring diagram available under the same number

1) See engineering and fitting notes for open circuits

2) At temperatures of less than 0 °C use stuffing box, above 100 °C use temperature adapter (accessory).



T10638



Y07544

Closure against the pressure

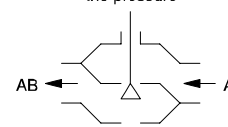

Closure with the pressure

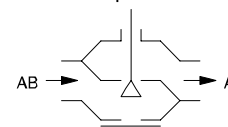

B01138

Combination VUN with electrical drive

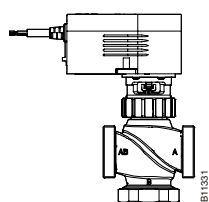

Drive	250 N pushing force					
Type:	AVM 105 F ...		AVM 105S F ...			
Running time:	30 s / 120 s		35 s / 60 s / 120 s			
Input:	2pt / 3pt		0...10 V			
Valve	Against the pressure			AVM 105 F12 .	AVM 105 F100	AVM 105S F ...
	Δp_{max}	Δp_s	close/off pressure			
VUN 015	4	–	6			
VUN 020	4	–	6			
VUN 025	4	–	5			
VUN 032	3	–	3			
VUN 040	1,9	–	1,9			
VUN 050	1	–	1,2			

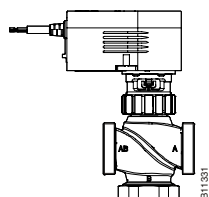

Drive	500 N pushing force							
Type:	AVM 115 F ...		AVM 115S F ...					
Running time:	120 s		60 s / 120 s					
Input:	2pt / 3pt		0...10 V					
Valve	Against the pressure			With the pressure			AVM 115	AVM 115S
	Δp_{max}	Δp_s	close/off pressure	Δp_{max}	Δp_s	close/off pressure		
VUN 015	6	–	15	–	–	–		
VUN 020	5	–	10	–	–	–		
VUN 025	4	–	7,5	–	–	–		
VUN 032	3,5	–	6	–	–	–		
VUN 040	3	–	3,6	–	–	–		
VUN 050	2,4	–	2,4	–	–	–		

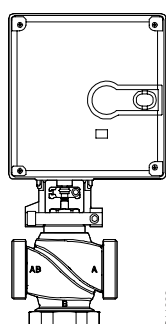

Drive	800 N pushing force							
Type:	AVM 124 F ...		AVM 125S F ...					
Running time:	30 s / 60 s / 120 s		30 s / 60 s / 120 s					
Input:	3pt		0...10 V or 2pt or 3pt					
Valve	Against the pressure			With the pressure			AVM 124	AVM 125S
	Δp_{max}	Δp_s	close/off pressure	Δp_{max}	Δp_s	close/off pressure		
VUN 015	8	–	15	6	–	15		
VUN 020	8	–	10	6	–	10		
VUN 025	8	–	9	5	–	9		
VUN 032	6	–	7	4	–	7		
VUN 040	5	–	6	2,5	–	6		
VUN 050	3	–	3,5	1,5	–	3,5		

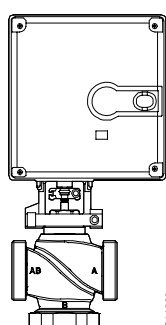

Drive	500 N pushing force							
Type:	AVF 124 F ...		AVF 125S F ...					
Running time:	60 s / 120 s		60 s / 120 s					
Input:	3pt		0...10 V or 2pt or 3pt					
Spring return:	18 ± 10 s		18 ± 10 s					
Valve	Against the pressure			With the pressure			AVF 124	AVF 125S
	Δp_{max}	Δp_s	close/off pressure	Δp_{max}	Δp_s	close/off pressure		
VUN 015	6	16	16	4	16	16		
VUN 020	5	12	12	2,8	16	12		
VUN 025	4	8	8	2,8	16	8		
VUN 032	3,5	6	6	2	16	6		
VUN 040	3	3,5	3,6	1,5	16	3,5		
VUN 050	2,4	2,4	2,4	0,8	16	2,4		

Valve: Variant F, for technical data and accessories see Valve Type Table

Drive: Variant F, for technical data, accessories and installation position see section 51

Example: VUN 015 F310 / AVM 115S F132

Δp_{max} [bar] Maximum permitted pressure difference over the valve at which the drive can still reliably open and close the valve, taking account of Δp_v .

Δp_s [bar] Maximum permitted pressure difference over the valve in case of a fault (pipe break downstream of the valve) at which the drive can close the valve reliably with "fast" performance of the stroke.

close/off pressure Maximum possible pressure difference over the valve in control mode, at which the drive can still open and close the valve. A reduced lifetime must be expected with this mode. Cavitation, erosion and pressure surges can damage the valve. The values are only valid for the assembled combination valve fitted on the drive.

Function

The valve can be controlled to any intermediate position using an electric drive. The valve is closed when the valve stem is extended. The closing procedure against the operating pressure is possible with valve drive AVM 105(S), 115S, 124, 125S or valve drive with spring return AVF 124, 125S. The closing procedure with the operating pressure is only permitted with AVM 124, 125S and AVF 124, 125S.

Closing procedure against the pressure

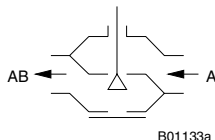

Closing procedure with the pressure

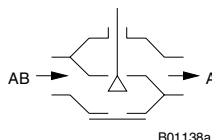

Description

These control valves are characterised by being extremely reliable and accurate, and make a considerable contribution to providing environmentally friendly control. They comply with the most demanding requirements such as a quick-closing function, handling differential pressures, controlling media temperatures and providing a shut-off facility – all with a low-noise design.

The valve stem is automatically and firmly connected to the drive shaft. This allows closing against or with the operating pressure to take place. It eliminates plug fluttering in the final position and also prevents cavitation and erosion from occurring at an early stage. Since there is no spring power to counteract the closing of the valve, the full power of the drive is available for the permissible pressure difference. The brass plug ensures that there is an equal-percentage flow in the control passage (exception VUN 050 F200: linear flow). The tightness of the valve is ensured by the seat in the body and the fibre glass-reinforced Teflon seal on the plug.

The stuffing box is maintenance-free. This consists of a brass body, 2 O-rings, a scraper ring and a supply of grease. This is silicon-free, i.e. silicon oil must not be used for the stems.

Engineering and fitting notes

The valves are combined with the valve drives with or without spring return. The drive is directly attached to the valve and secured using a nut or bolts. The drive is connected to the valve stem automatically. During initial commissioning of the system the drive moves out and the lock closes automatically when it reaches the lower valve seat. The stroke of the valve is also detected by the drive, meaning that no other settings are required. The force on the seat is therefore always consistent and ensures that the leakage rate is minimal. The characteristic curve of the SUT drives can be set to linear or quadratic. The combination of the AVM 105S and the DN 50 F200 cannot be switched to equal percentage, use AVM 115S.

In order to prevent impurities from being retained in the water (e.g. welding beads, rust particles etc.) and damaging the stem seal, collective filters must be installed on each floor or in each feed pipe. For water requirements see VDI 2035.

All valves must only be used in closed circuits. Excessive oxygen content in open circuits can destroy the valve. In order to prevent this, an oxygen binding material must be used; the manufacturer of the solution must be consulted with regard to compatibility in order to prevent corrosion.

The material list can be used for this purpose.

The valves are usually insulated in the systems. Care must be taken not to insulate the collar that holds the drive when doing this. A stuffing box heater must also never be insulated.

In order to prevent disturbing flow noise in quiet rooms, the pressure difference across the valve must not exceed 50% of the specified values.

The manual operation facility (accessory) is fitted to the valve like a drive. The connection to the valve shaft takes place automatically when the valve is opened with the knob.

Application with water

When water is used that has been mixed with glycol or inhibitor, compatibility with the materials and seals in the valve should be clarified with the manufacturer for safety reasons. The table of materials shown below can be used for this purpose. We recommend using a concentration of between 20% and 55% when glycol is being used.

The valves are not suitable for use in potentially explosive areas. The materials that have been selected are approved for use with drinking water. The entire valve as a unit is not certified for use with drinking water.

Installation position

The final control element can be installed in any position, but a suspended installation position is not recommended. Condensation and dripping water must be prevented from penetrating the drive.

Flow rate chart

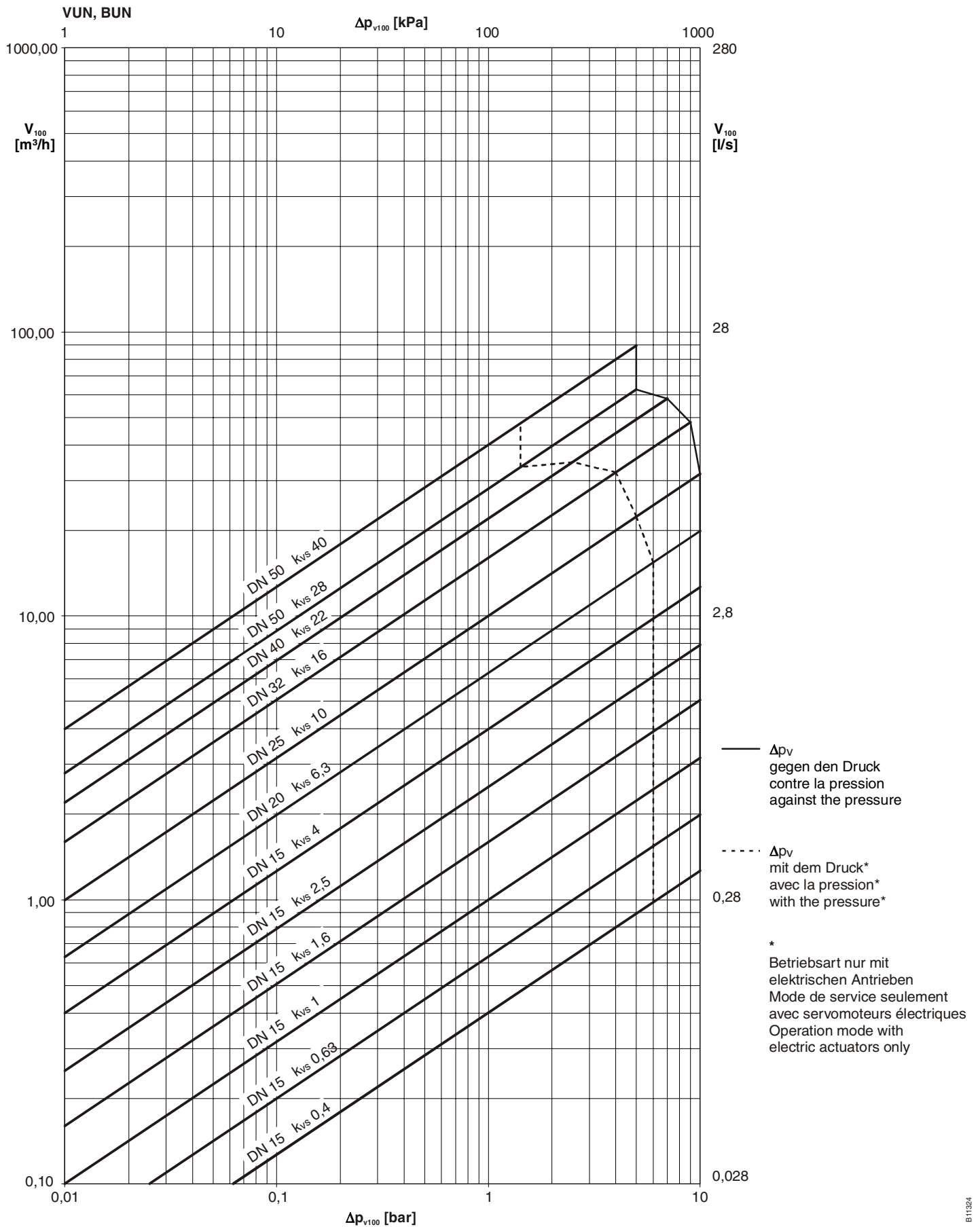

Type	Δp_v	
	Against the pressure	With the pressure
VUN 015 F350	10	6
VUN 015 F340	10	6
VUN 015 F330	10	6
VUN 015 F320	10	6
VUN 015 F310	10	6
VUN 015 F300	10	6
VUN 020 F300	10	6
VUN 025 F300	10	5
VUN 032 F300	9	4
VUN 040 F300	7	2,5
VUN 050 F300	5	1,5
VUN 050 F200	5	1,5

Additional technical data

Technical Information

- Pressure and temperature specifications	EN 764, EN 1333
- Fluidic parameters	EN 60534 page 3
- Sauter slide rule for valve dimensioning	7 090011 003
- Slide rule manual	7 000129 003
- Technical handbook "Actuators"	7 000477 003
- Parameters, installation instructions, control, general	Applicable EN, DIN, AD, TRD and UVV instructions
- Pressurised equipment CE conformity directive, no CE symbol (fluid group II)	97/23/EG Article 3.3

Further information

Valve body made from dezincification-free chilled casting (EN 1982) with male thread, cylindrical in accordance with ISO 228/1 class B, flat seal on body. Stuffing box with double ethylene propylene O-ring.

DIN material numbers

	DIN material number	DIN designation
Valve body	CC752S-GM	Cu Zn 35 Pb 2 Al-C
Valve seat	CC752S-GM	Cu Zn 35 Pb 2 Al-C
Spindle	1.4305	X 8 Cr Ni S 18-9 + 1G
Plug	CW 602 N	Cu Zn 36 Pb 2 As
Plug seal	PTFE	
Stuffing box	CW 602 N	Cu Zn 36 Pb2 As

Amplified information on pressure difference definitions

Δp_V :

Maximum permissible pressure difference across the valve in any stroke position, limited by the noise level and erosion.

The valve as a traversed element is defined by this parameter specifically in its hydraulic behaviour. By monitoring cavitation, erosion and the noise thus produced, improvements can be achieved in both life expectancy and durability.

Δp_{max} :

Maximum permissible pressure difference across the valve at which the drive can firmly open and close the valve.

Static pressure and fluidic influences are taken into account. This value helps to maintain a smooth stroke action and the high level of sealing. In doing so, the valve's Δp_V value is never exceeded.

Δp_S :

Maximum permissible pressure difference across the valve in the event of a malfunction (e.g. power failure, excess temperature or pressure, burst pipe) at which the drive can firmly close the valve and, if necessary, hold the full operating pressure against atmospheric pressure. Since this is a quick-close functions with 'fast' stroke, Δp_S can be larger than Δp_{max} or, respectively, Δp_V . The resultant fluidic disturbances are soon overcome and play a minor role here.

On the three-way valves, the values apply only for the control passage.

Δp_{stat} :

Line pressure behind the valve. This corresponds largely to the dead pressure when the pump is switched off, e.g. due to the level of liquid in the installation, an increase in pressure via the pressure store, steam pressure etc.

For valves that close with the pressure, the static pressure plus the pump pressure should be used.

Characteristic for drives with positioners

On drive AVM 105S or AVM 115S

Equal percentage / linear

On drive AVM 125S or AVF 125S

Equal percentage / linear / quadratic

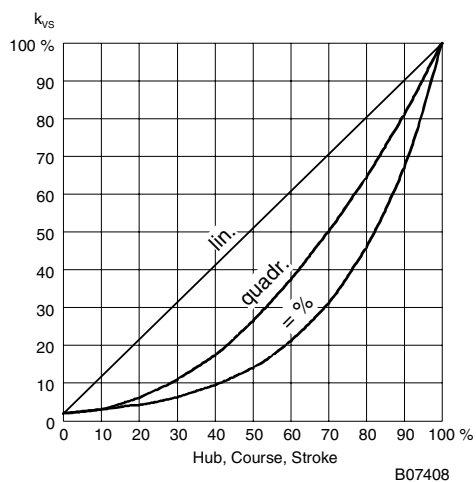

Dimension drawings

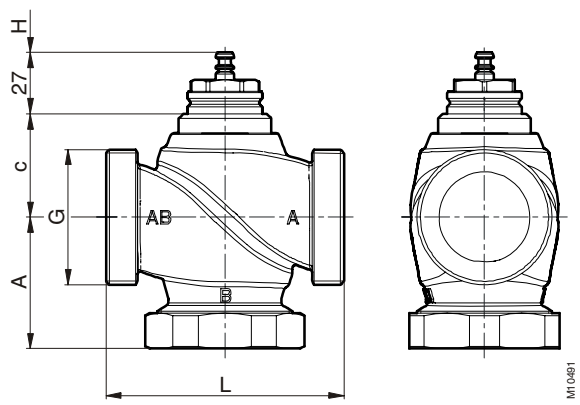

DN	A	c	L	H	G
15	58,5	45,5	100	8	G 1"
20	58,0	38,5	100	8	G 1 1/4"
25	60,7	42,5	105	8	G 1 1/2"
32	62,5	45,5	105	8	G 2"
40	75,0	59,0	130	8	G 2 1/4"
50	87,0	67,5	130	8	G 2 3/4"

Combinations

AVM 105(S), 115(S)

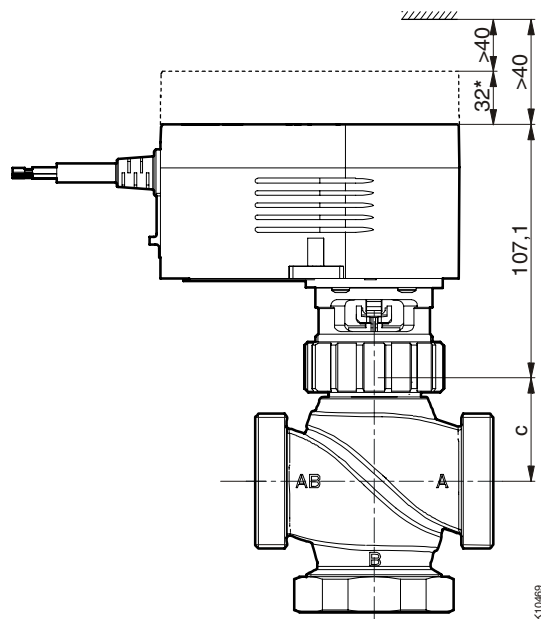

AVM, AVF 124, 125S

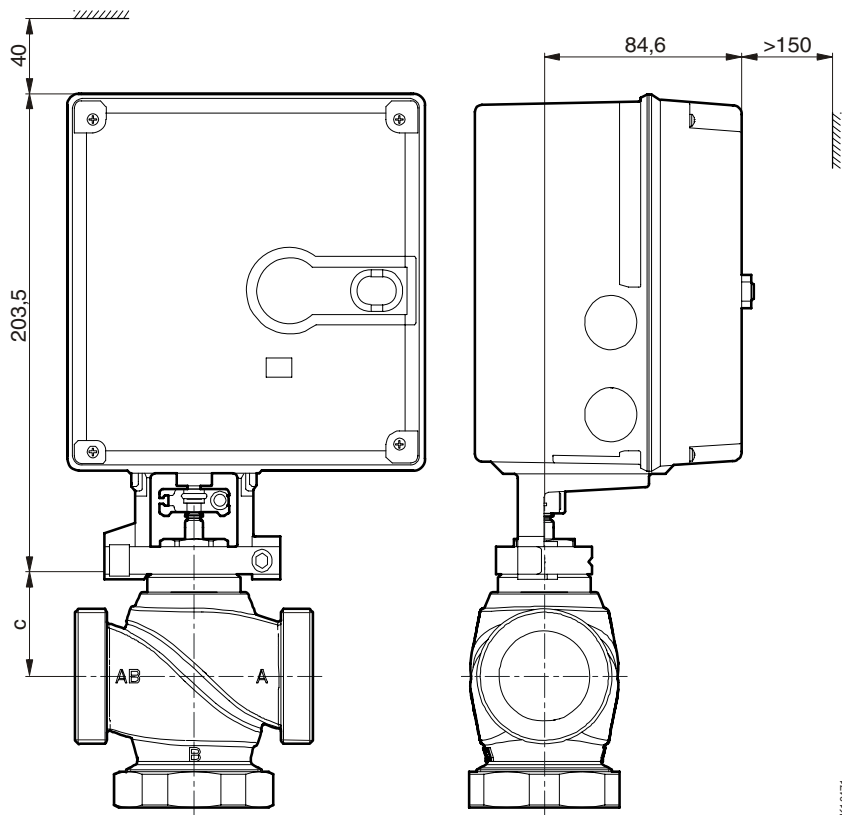

* with accessory 372145, 372286

Accessories

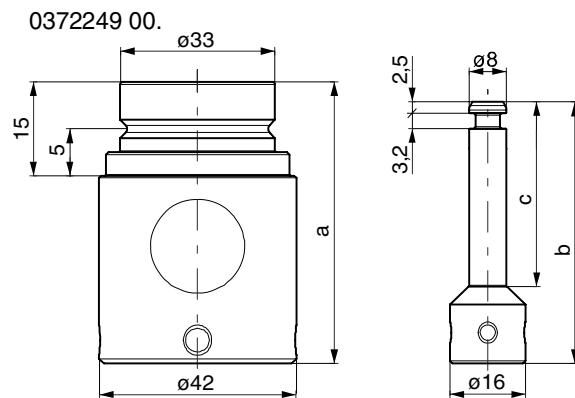
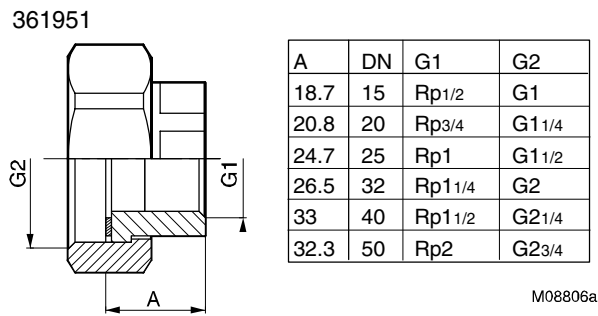
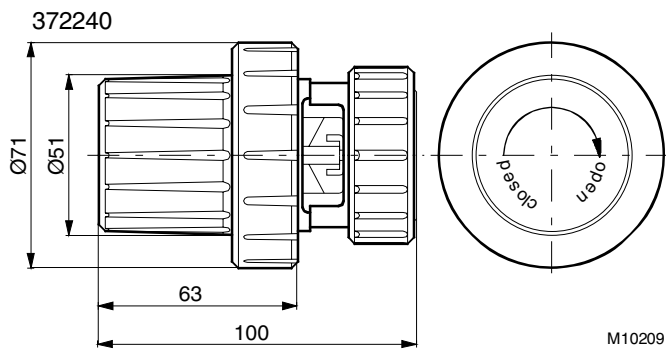

	a [mm]	b [mm]	c [mm]
0372249 001	60	55,8	40
0372249 002	80	75,8	60

Z10220

